

JVC

SERVICE MANUAL

AUDIO VIDEO CONTROL RECEIVER

RX-554RBK_E

Area Suffix	
B	U.K.
E	Continental Europe
EE	East Europe
EN	North Europe

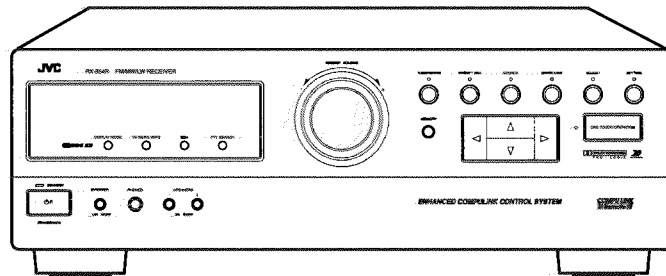
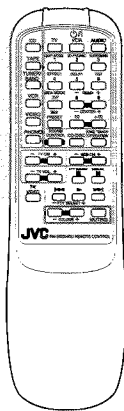

COMPU LINK
/// Remote ///

DOLBY SURROUND
 PRO · LOGIC

3D
 3D-PHONIC

R·D·S EON

Contents

Safety Precautions	1-2	Adjustment Procedures	2-16
Instruction Book	1-4~27	Block Diagrams	2-17
Description of Major ICs	2-1	Schematic Diagrams	2-19
Internal Connection of Display	2-13	Printed Circuit Boards	2-24~27
Disassembly Procedures	2-14	Parts List	3-1~13



Safety Precautions

1. This design of this product contains special hardware and many circuits and components specially for safety purposes. For continued protection, no changes should be made to the original design unless authorized in writing by the manufacturer. Replacement parts must be identical to those used in the original circuits. Services should be performed by qualified personnel only.
2. Alterations of the design or circuitry of the product should not be made. Any design alterations of the product should not be made. Any design alterations or additions will void the manufacturer's warranty and will further relieve the manufacture of responsibility for personal injury or property damage resulting therefrom.
3. Many electrical and mechanical parts in the products have special safety-related characteristics. These characteristics are often not evident from visual inspection nor can the protection afforded by them necessarily be obtained by using replacement components rated for higher voltage, wattage, etc. Replacement parts which have these special safety characteristics are identified in the Parts List of Service Manual. Electrical components having such features are identified by shading on the schematics and by (\triangle) on the Parts List in the Service Manual. The use of a substitute replacement which does not have the same safety characteristics as the recommended replacement parts shown in the Parts List of Service Manual may create shock, fire, or other hazards.
4. The leads in the products are routed and dressed with ties, clamps, tubings, barriers and the like to be separated from live parts, high temperature parts, moving parts and/or sharp edges for the prevention of electric shock and fire hazard. When service is required, the original lead routing and dress should be observed, and it should be confirmed that they have been returned to normal, after re-assembling.

5. Leakage current check (Electrical shock hazard testing)

After re-assembling the product, always perform an isolation check on the exposed metal parts of the product (antenna terminals, knobs, metal cabinet, screw heads, headphone jack, control shafts, etc.) to be sure the product is safe to operate without danger of electrical shock.

Do not use a line isolation transformer during this check.

- Plug the AC line cord directly into the AC outlet. Using a "Leakage Current Tester", measure the leakage current from each exposed metal parts of the cabinet, particularly any exposed metal part having a return path to the chassis, to a known good earth ground. Any leakage current must not exceed 0.5mA AC (r.m.s.)

● Alternate check method

Plug the AC line cord directly into the AC outlet. Use an AC voltmeter having, 1,000 ohms per volt or more sensitivity in the following manner. Connect a 1,500 Ω 10W resistor paralleled by a 0.15 μ F AC-type capacitor between an exposed metal part and a known good earth ground.

Measure the AC voltage across the resistor with the AC voltmeter.

Move the resistor connection to each exposed metal part, particularly any exposed metal part having a return path to the chassis, and measure the AC voltage across the resistor. Now, reverse the plug in the AC outlet and repeat each measurement. voltage measured Any must not exceed 0.75 V AC (r.m.s.). This corresponds to 0.5 mA AC (r.m.s.).

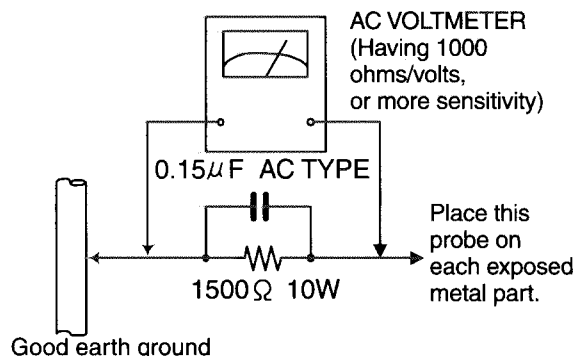

Warning

1. This equipment has been designed and manufactured to meet international safety standards.
2. It is the legal responsibility of the repairer to ensure that these safety standards are maintained.
3. Repairs must be made in accordance with the relevant safety standards.
4. It is essential that safety critical components are replaced by approved parts.
5. If mains voltage selector is provided, check setting for local voltage.

CAUTION Burrs formed during molding may be left over on some parts of the chassis. Therefore, pay attention to such burrs in the case of preforming repair of this system.

Safety Precautions (U.K only)

1. This design of this product contains special hardware and many circuits and components specially for safety purposes. For continued protection, no changes should be made to the original design unless authorized in writing by the manufacturer. Replacement parts must be identical to those used in the original circuits.
2. Any unauthorised design alterations or additions will void the manufacturer's guarantee ; furthermore the manufacturer cannot accept responsibility for personal injury or property damage resulting therefrom.
3. Essential safety critical components are identified by () on the Parts List and by shading on the schematics, and must never be replaced by parts other than those listed in the manual. please note however that many electrical and mechanical parts in the product have special safety related characteristics. These characteristics are often not evident from visual inspection. Parts other than specified by the manufacturer may not have the same safety characteristics as the recommended replacement parts shown in the Parts List of the Service Manual and may create shock, fire, or other hazards.
4. The leads in the products are routed and dressed with ties, clamps, tubings, barriers and the like to be separated from live parts, high temperature parts, moving parts and/or sharp edges for the prevention of electric shock and fire hazard. When service is required, the original lead routing and dress should be observed, and it should be confirmed that they have been returned to normal, after re-assembling.

Warning

1. Service should be performed by qualified personnel only.
2. This equipment has been designed and manufactured to meet international safety standards.
3. It is the legal responsibility of the repairer to ensure that these safety standards are maintained.
4. Repairs must be made in accordance with the relevant safety standards.
5. It is essential that safety critical components are replaced by approved parts.
6. If mains voltage selector is provided, check setting for local voltage.

 **CAUTION** Burrs formed during molding may be left over on some parts of the chassis. Therefore, pay attention to such burrs in the case of performing repair of this system.

RX554RBK

Instruction Book



JVC

FM/MW/LW RECEIVER
UKW/MW/LW-RECEIVER
AMPLI/TUNER FM/PO/GO
FM/MG/LG TUNER/VERSTERKER
RECEPTOR FM/MW/LW
RICEVITORE MF/OM/OL

RX-554RBK

JVC

VICTOR COMPANY OF JAPAN, LIMITED

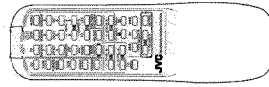

COMPU LINK
Remote III

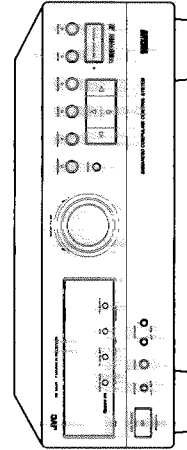

INSTRUCTIONS

BEDIENUNGSANLEITUNG
MANUEL D'INSTRUCTIONS
GEBRUIKSAANWIJZING
MANUAL DE INSTRUCCIONES
ISTRUZIONI

For Customer Use:
Enter below the Model No. and Serial No. which are located either on the rear bottom or side of the cabinet. Retain this information for future reference.

Model No. _____
Serial No. _____

LET0118-001A
(E, EE)

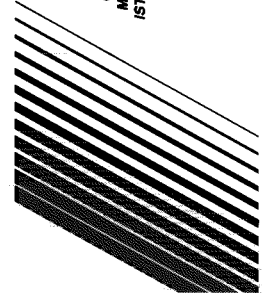

0280RM/DVUEN

EN, GE, FR, NL, SP, IT

**Warnings, Cautions and Others/Warning, Achtung und sonstige Hinweise/
Mises en garde, précautions et Indications diverses/Waarschuwingen,
voorzorgen en andere mededelingen/Avisos, precauciones y otras notas/
Avvertenze e precauzioni da osservare**

IMPORTANT for the U.K.
DO NOT cut off the mains plug from this equipment. If the plug fitted is not suitable for the power points in your home or the cable is damaged, contact your local authority or an appropriate safety approved extension lead or consult your dealer.
BE SURE to replace the fuse only with an identical approved type, as originally fitted.
If nonetheless the mains plug is cut off, ensure to remove the fuse immediately and do not touch the plug as it may give a shock hazard by inadvertent connection to the mains supply.
If this product is not supplied fitted with a mains plug then follow the instructions given below.
IMPORTANT.
DO NOT make any connection to the terminal which is marked with the letter E or by the safety earth symbol or coloured green or green-and-yellow.
The wires in the mains lead on this product are coloured in accordance with the following code:
Blue : Neutral
Brown : Live
As these colours may not correspond with the coloured markings identifying the terminals in your plug proceed as follows:
The wire which is coloured blue must be connected to the terminal which is marked with the letter N or coloured black.
The wire which is coloured brown must be connected to the terminal which is marked with the letter L or coloured red.
IF IN DOUBT - CONSULT A COMPETENT ELECTRICIAN.

Per l'Italia:
"Si dichiara che il questo prodotto di marca JVC è conforme alle prescrizioni del Decreto Ministeriale n.548 del 29/08/95 pubblicato sulla Gazzetta Ufficiale della Repubblica Italiana n.301 del 28/12/95."

CAUTION

To reduce the risk of electrical shocks, fire, etc.:
1. Do not remove screws, covers or cabinet.
2. Do not expose this appliance to rain or moisture.

ACHTUNG

Zur Verhinderung von elektrischen Schlägen, Brandgefahr, usw.:
1. Keine Schrauben lösen oder Abdeckungen entfernen und nicht das Gehäuse öffnen.
2. Dieses Gerät weder Regen noch Feuchtigkeit aussetzen.

ATTENTION

Afin d'éviter tout risque d'électrocution, d'incendie, etc.:
1. Ne pas enlever les vis ni les panneaux et ne pas ouvrir le coffret de l'appareil.
2. Ne pas exposer l'appareil à la pluie ni à l'humidité.

VOORZICHTIG

Ter vermindering van gevaar voor brand, elektrische schokken, enz.:
1. Verwijder geen schroeven, panelen of de behuizing.
2. Stel dit toestel niet bloot aan regen of vocht.

PRECAUCION

Para reducir riesgos de choques eléctricos, incendio, etc.:
1. No extraiga los tornillos, los cubiertas ni la caja.
2. No exponga este aparato a la lluvia o a la humedad.

ATTENZIONE

Per ridurre il rischio di scosse elettriche, incendi, ecc...
1. Non togliere viti, coparchi o la scatola.
2. Non esporre l'apparecchio alla pioggia e all'umidità.

English

Deutsch

Français

Nederlands

Español

Italiano

RX554RBK

Caution — Ⓞ **POWER switch and STANDBY/ON** Ⓞ/Ⓞ/Ⓞ **button!**
 This apparatus is provided with a Ⓞ **POWER switch** to be able to minimize power consumption for safe use. Therefore,
 1. When doing initial setting, complete all the connections required, connect the mains plug into the wall outlet, and set the Ⓞ **POWER switch** to ON. After these, it will be available to operate **STANDBY/ON** Ⓞ/Ⓞ/Ⓞ button and so on.
 2. When not in use, set the Ⓞ **POWER switch** to OFF.
 3. Disconnect the mains plug to shut the power off completely. The Ⓞ **POWER switch** and **STANDBY/ON** Ⓞ/Ⓞ/Ⓞ button in any position do not disconnect the mains line.
 4. The power can be remote controlled.

Achtung — Ⓞ **POWER-Schalter** und **STANDBY/ON** Ⓞ/Ⓞ/Ⓞ **Taste!**
 Dieses Gerät hat einen Netzschalter (Ⓞ **POWER**), um den Stromverbrauch für sichere Verwendung auf ein Minimum bringen zu können. Verfahren Sie deshalb wie folgt:
 1. Beim ursprünglichen Aufbau alle erforderlichen Anschlüsse herstellen, den Netzstecker in eine Wandsteckdose stecken, und den Ⓞ **POWER-Schalter** einschalten. Anschließend ist Betrieb der **STANDBY/ON** Ⓞ/Ⓞ/Ⓞ-Taste usw. möglich.
 2. Wenn das Gerät nicht verwendet wird, den Ⓞ **POWER-Schalter** ausschalten.
 3. Den Netzstecker aus der Steckdose ziehen, um die Stromversorgung vollkommen zu unterbrechen. Der Ⓞ **POWER-Schalter** und die **STANDBY/ON** Ⓞ/Ⓞ/Ⓞ-Taste unterbrechen in keiner Stellung die Stromversorgung vollkommen.
 4. Die Stromversorgung kann mit der Fernbedienung ein- und ausgeschaltet werden.

Attention — Commutateur Ⓞ **POWER** et d'une touche **STANDBY/ON** Ⓞ/Ⓞ/Ⓞ
 Cet appareil est équipé d'un commutateur Ⓞ **POWER** qui lui permet de réduire sa consommation d'électricité pour une utilisation plus sûre. Par conséquent,
 1. En procédant au réglage initial, compléter toutes les connexions nécessaires, connecter la fiche secteur dans la prise murale et mettre le commutateur Ⓞ **POWER** sur la position ON. Ensuite, il sera possible de contrôler la touche **STANDBY/ON** Ⓞ/Ⓞ/Ⓞ, etc.
 2. Mettre le commutateur Ⓞ **POWER** sur la position OFF lorsque l'appareil n'est pas utilisé.
 3. Déconnecter la fiche secteur pour couper complètement le courant. Le commutateur Ⓞ **POWER** et la touche **STANDBY/ON** Ⓞ/Ⓞ/Ⓞ ne coupent jamais complètement l'alimentation, quelle que soit leurs positions.
 4. L'alimentation peut être télécommandée.

Voorzichtig — Ⓞ **POWER** en **STANDBY/ON** Ⓞ/Ⓞ/Ⓞ **schakelaar!**
 Dit apparaat is voorzien van een Ⓞ **POWER** hoofdschakelaar om het apparaatgebruikskaart te zetten, maar te zorgen dat het stroomverbruik minimaal blijft. Neem in verband hiermee het volgende in acht:
 1. Bij de eerste ingebruikneming zorgt u eerst dat alle aansluitingen in orde zijn, dan steekt u de stekker in het stopcontact en dan zet u de Ⓞ **POWER** schakelaar in de "ON" stand. Daarna kunt u het apparaat aan- en uitschakelen met de **STANDBY/ON** Ⓞ/Ⓞ/Ⓞ schakelaar.
 2. Wanneer u het apparaat geruime tijd niet gebruikt, kunt u beter de Ⓞ **POWER** schakelaar in de "OFF" stand zetten.
 3. Om de stroom te stoppen, moet u de stekker uit het stopcontact. Anders zal er altijd stroom lopen, ongeacht de stand van de **STANDBY/ON** Ⓞ/Ⓞ/Ⓞ en de Ⓞ **POWER**.
 4. U kunt het apparaat ook met de afstandsbediening aan- en uitschakelen.

Precución — Interruptor Ⓞ **POWER** / botón **STANDBY/ON** Ⓞ/Ⓞ/Ⓞ
 Esta unidad dispone de un interruptor Ⓞ **POWER** que sirve para reducir al mínimo el consumo de alimentación para proporcionar mayor seguridad operacional. Por lo tanto,
 1. Al ejecutar el ajuste inicial, después de completar todas las conexiones requeridas, conectar el cable de alimentación a una toma de pared, y activar el interruptor Ⓞ **POWER**. Entonces, será posible ejecutar operaciones tales como la conmutación del estado de alimentación.
 2. Desactivar el interruptor Ⓞ **POWER** al dejar la unidad fuera de uso.
 3. Desconectar el cable de alimentación para desactivar la alimentación total. Cualquier otro cable de alimentación conectado al interruptor Ⓞ **POWER** y al botón **STANDBY/ON** Ⓞ/Ⓞ/Ⓞ, la alimentación no es controlada completamente.
 4. La alimentación puede ser controlada remotamente.

Attenzione — interruttore Ⓞ **POWER** e tasto **STANDBY/ON** Ⓞ/Ⓞ/Ⓞ
 Per ridurre al minimo l'assorbimento di corrente al fine della sicurezza, questo apparecchio è stato dotato di un interruttore Ⓞ **POWER**. Di conseguenza,
 1. Al momento dell'impostazione iniziale, completare tutti i collegamenti richiesti, inserire la spina del cavo di alimentazione nella presa a muro della rete elettrica e impostare l'interruttore Ⓞ **POWER** in posizione ON. Fatto ciò, sarà pronto all'uso **STANDBY/ON** Ⓞ/Ⓞ/Ⓞ.
 2. Quando non in uso, impostare l'interruttore Ⓞ **POWER** in posizione OFF.
 3. Disinserire la spina del cavo di alimentazione dalla presa della rete elettrica per disattivare completamente l'alimentazione. L'interruttore Ⓞ **POWER** e il tasto **STANDBY/ON** Ⓞ/Ⓞ/Ⓞ, in nessuna posizione staccano la rete di alimentazione elettrica principale.
 4. È possibile il controllo remoto dell'alimentazione.

Caution: Proper Ventilation
 To avoid risk of electric shock and fire and to protect from damage. Locate the apparatus as follows:
 Front: No obstructions open spacing
 Sides: No obstructions in 10 cm from the sides.
 Top: No obstructions in 10 cm from the top.
 Back: No obstructions in 15 cm from the back.
 Bottom: No obstructions, place on the level surface.
 In addition, maintain the best possible air circulation as illustrated.

Achtung: Angemessene Ventilation
 Stellen Sie das Gerät zur Verhütung von elektrischem Schlag und Feuer und zum Schutz gegen Beschädigung wie folgt auf:
 Vorderseite: Offener Platz ohne Hindernisse.
 Seiten: Keine Hindernisse innerhalb 10 cm von den Seiten.
 Oberseite: Keine Hindernisse innerhalb 10 cm von der Oberseite.
 Rückseite: Keine Hindernisse innerhalb 15 cm von der Rückseite.
 Unterseite: Keine Hindernisse. Auf eine ebene Oberfläche stellen.
 Zusätzlich die bestmögliche Luftzirkulation wie gezeigt erhalten.

Attention: Ventilation Correcte
 Pour éviter les chocs électriques, l'incendie et tout autre dégât. Disposer l'appareil en tenant compte des impératifs suivants
 Avant: Rien ne doit gêner le dégagement
 Flancs: Laisser 10 cm de dégagement latéral
 Dessus: Laisser 10 cm de dégagement supérieur
 Arrière: Laisser 15 cm de dégagement arrière
 Dessous: Rien ne doit obstruer par dessous; poser l'appareil sur une surface plate.
 Veiller également à ce que l'air circule le mieux possible comme illustré.

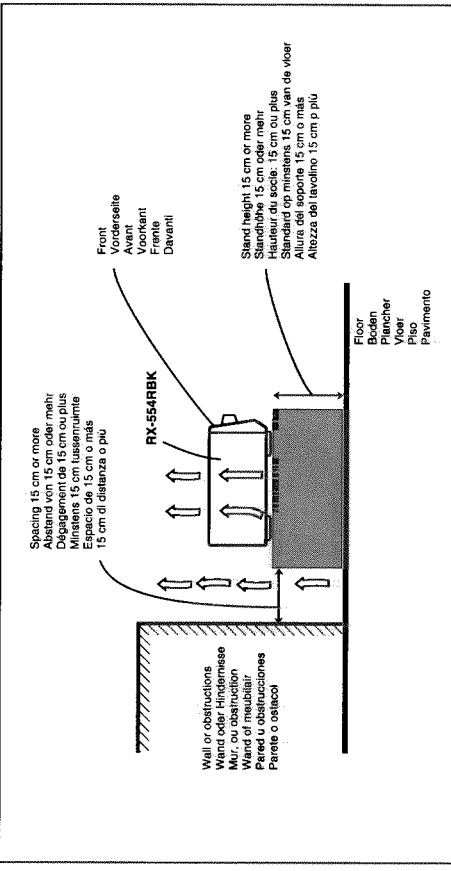

Voorzichtig: Zorg Voor Goede Ventilatie
 Om gevaar voor brand of een elektrische schok te voorkomen, dient u bij opstelling van het apparaat op de volgende punten te letten:
 Voorkant: Voldoende ruimte vrij houden.
 Zijkanten: Minstens 10 cm aan weerszijden vrij houden.
 Bovenkant: Niets bovenop plaatsen; 10 cm speling geven.
 Achterkant: Minstens 15 cm ruimte achteraan vrij houden.
 Onderkant: Opstellen op een egaal horizontaal oppervlak.
 Bovendien moet er rondom voldoende luchttoevoer zijn, zoals in de afbeelding aangegeven.

Precución: Ventilación Adecuada
 Para evitar el riesgo de choque eléctrico e incendio y para proteger el aparato contra daños.
 Ubique el aparato de la siguiente manera:
 Frente: Espacio abierto sin obstrucciones
 Lados: 10 cm sin obstrucciones a los lados
 Parte superior: 10 cm sin obstrucciones en la parte superior
 Parte trasera: 15 cm sin obstrucciones en la parte trasera
 Fondo: Sin obstrucciones; colóquelo sobre una superficie nivelada
 Además, mantenga la mejor circulación de aire posible como se ilustra.

Attenzione: Problemi di Ventilazione
 Per evitare il rischio di folgorazioni ed incendi e proteggere l'unità da danni, installarla nel modo seguente.
 Davanti: Nessun ostacolo, spazio libero
 Lati: Nessun ostacolo per almeno 10 cm
 Sopra: Nessun ostacolo per almeno 10 cm
 Retro: Nessun ostacolo per almeno 15 cm
 Fondo: Libero ed in piano
 Inoltre, mantenere il più possibile la circolazione dell'aria.

Table of Contents

- Parts Identification**..... 2
- Getting Started**..... 3
 - Before Installation..... 3
 - Checking the Supplied Accessories..... 3
 - Connecting the FM and AM (MW/LW) Antennas..... 4
 - Connecting the Speakers..... 4
 - Connecting Other Components..... 7
 - Connecting the Power Cord..... 8
 - Putting Batteries in the Remote Control..... 8
- Basic Operations**..... 9
 - Turning the Power On and Off (Standby)..... 9
 - Selecting the Source to Play..... 9
 - Adjusting the Volume..... 10
 - Selecting the Front Speakers..... 10
 - Muting the Sound..... 10
 - Recording a Source..... 11
 - Listening with Headphones..... 11
- Basic Settings**..... 12
 - Adjusting the Front Speaker Output Balance..... 12
 - Listening at Low Volume (Loudness)..... 12
 - Using the Sleep Timer..... 13
 - Selecting the Center Speaker Size..... 14
- One Touch Operation**..... 14
 - About the One Touch Operation..... 14
 - Using the One Touch Operation..... 14
- Receiving Radio Broadcasts**..... 15
 - Tuning in Stations Manually..... 15
 - Using Preset Tuning..... 15
 - Selecting the FM Reception Mode..... 17
 - Using the RDS (Radio Data System) to Receive FM Stations..... 17
 - What Information Can RDS Signals Provide?..... 18
 - Searching for a Program by PTY Codes..... 19
 - Switching to a Broadcast Program of Your Choice Temporarily..... 22
- Using the Preset SEA Modes**..... 24
 - Selecting Your Favorite SEA Mode..... 24
- Activating the Surround Sounds**..... 26
 - Using JVC 3D-PHONIC Modes..... 27
 - Using the DAP Modes..... 29
 - Speaker Arrangements for Surround Modes..... 31
 - Preparing for Surround Modes..... 32
 - Using Surround Modes..... 36
- COMPU LINK Remote Control System**..... 37
- Operating Other Components**..... 38
- Troubleshooting**..... 40
- Specifications**..... 41

Parts Identification

Become familiar with the buttons and controls on the receiver before use.

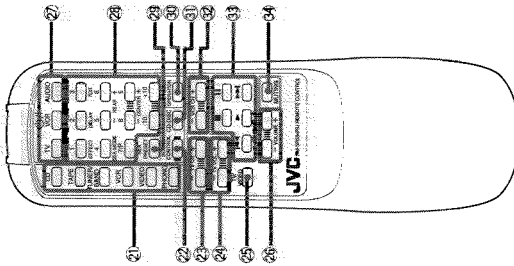
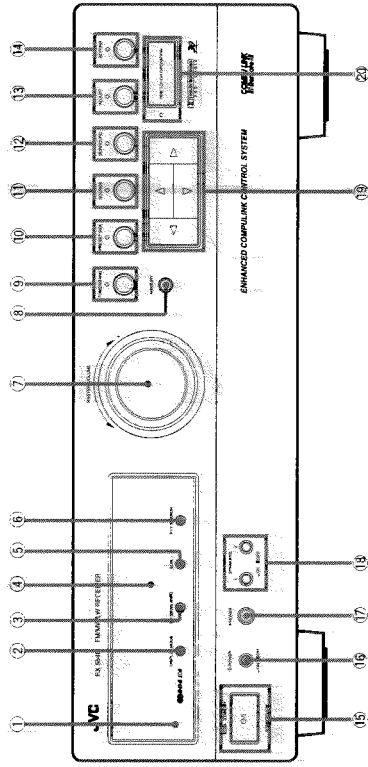

Refer to the pages in parentheses for details.

Front Panel

- ① Remote sensor (8)
- ② DISPLAY MODE button (18)
- ③ TA/NEWS/INFO button (22)
- ④ Display (9)
- ⑤ EON button (22)
- ⑥ PTY SEARCH button (19)
- ⑦ MASTER VOLUME control (10)
- ⑧ MEMORY button (15)
- ⑨ TUNER/BAND button and lamp (15)
- ⑩ PRESET SEA button and lamp (24)
- ⑪ SOURCE button and lamp (9)
- ⑫ SURROUND button and lamp (27, 29, 32, 36)
- ⑬ ADJUST button and lamp (27, 29, 32)
- ⑭ SETTING button and lamp (12, 13)
- ⑮ STANDBY/ON \odot/I button and STANDBY lamp (9)
- ⑯ POWER switch (8)
- ⑰ PHONES jack (11)
- ⑱ SPEAKERS I/2 buttons (10, 11)
- ⑲ Control $\Delta/\nabla/\leftarrow/\rightarrow$ buttons
- ⑳ ONE TOUCH OPERATION button and lamp (14)

Remote Control

- ㉑ Source buttons (CD, TAPE, TUNER/BAND, VCR, VIDEO, PHONO) (9, 38, 39)
- ㉒ SOUND CONTROL button (25, 28, 30, 34, 36)
- ㉓ TV/VIDEO button (39)
- ㉔ VOLUME buttons (+/-) (10)
- ㉕ \odot/I (Standby/On) buttons (TV, VCR, AUDIO) (9, 39)
- ㉖ 10 keys/Audio control buttons (16, 25, 28, 30, 34, 36)
- ㉗ SEA PRESET button (25)
- ㉘ ONE TOUCH OPERATION button (14)
- ㉙ CD-DISC button (38)
- ㉚ VCR CH (Channel) buttons (+/-) (39)
- ㉛ Operating buttons for JVC audio/video components and RDS operating buttons (18, 20, 38, 39)
- ㉜ MUTING button (10)

To use JVC VCR, cassette deck and CD player after adjusting preset SEA or surround modes using SOUND CONTROL, press the corresponding source button (VCR, TAPE or CD) prior to using JVC audio/video operating buttons (㉛).

- ㉜ TV CH (Channel) buttons (+/-) (39)
- ㉝ TV VOL. (Volume) buttons (+/-) (39)

Getting Started

This section explains how to connect stereo components and speakers to the receiver, and how to connect the power supply.

Before Installation

General

- Be sure your hands are dry.
- Turn the power off to all components.
- Read the manuals supplied with the components you are going to connect.

Locations

- Install the receiver in a location that is level and protected from moisture.
- The temperature around the receiver must be between -5° and 35° C (23° and 95° F).
- Make sure there is good ventilation around the receiver. Poor ventilation could cause overheating and damage the receiver.

Handling the receiver

- Do not insert any metal object into the receiver.
- Do not disassemble the receiver or remove screws, covers, or cabinet.
- Do not expose the receiver to rain or moisture.

Checking the Supplied Accessories

Check to be sure you have all of the following items, which are supplied with the receiver.

The number in the parentheses indicates quantity of the pieces supplied.

- Remote Control (1)
- Batteries (2)
- AM (MW/LW) Loop Antenna (1)
- FM Antenna (1)

If anything is missing, contact your dealer immediately.

Connecting the FM and AM (MW/LW) Antennas

FM Antenna Connections

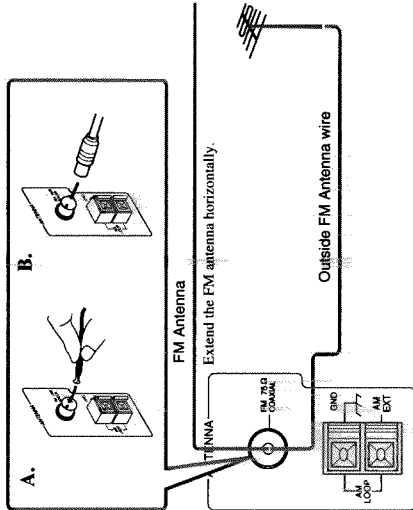

Note:
If reception is poor, connect the outside antenna.
Before attaching a 75 Ω coaxial cable (the kind with a round wire going to an outside antenna), disconnect the supplied FM wire antenna.

A. Using the Supplied FM Antenna

The FM antenna provided can be connected to the FM 75 Ω COAXIAL terminal as temporary measure.

B. Using the Standard Type Connector (Not supplied)

A standard type connector (IEC or DIN45325) should be connected to the FM 75 Ω COAXIAL terminal.

AM (MW/LW) Antenna Connections

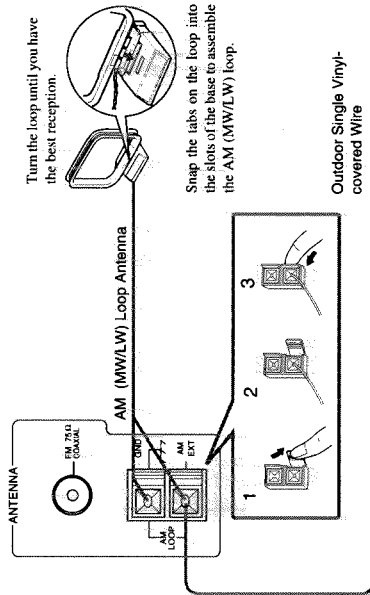

Turn the loop until you have the best reception.

Snap the tabs on the loop into the slots of the base to assemble the AM (MW/LW) loop.

Outdoor Single Vinyl-covered Wire

Notes:

- Make sure the antenna conductors do not touch any other terminals, connecting cords and power cord. This could cause poor reception.
- If reception is poor, connect an outdoor, single vinyl-covered wire to the AM EXT terminal. (Keep the AM (MW/LW) loop antenna connected.)

Getting Started

Connecting the Speakers

You can connect the following speakers:

- Two sets of front speakers to produce normal stereo sound
- One set of rear speakers to enjoy the surround effect
- One center speaker to produce more effective surround effect (to make human voices outstanding)

For each speaker, connect one end of the speaker signal cable (not supplied) to the speaker terminal on the rear panel and the other end to the speaker.

1. Open each terminal.
2. Insert the end of the speaker signal cable as shown (be sure to remove the insulation at the end of each wire first).
3. Close the terminals to clamp the speaker signal cables firmly in place.
4. Connect the (-) and (+) terminals on the rear panel to the (-) and (+) terminals marked on the speakers.

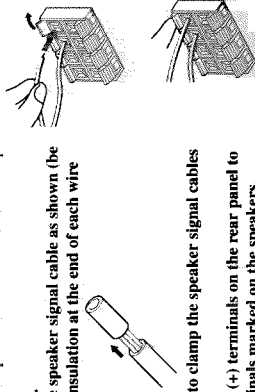

Connecting the front speakers

Connect the front speakers to the FRONT SPEAKERS terminals.

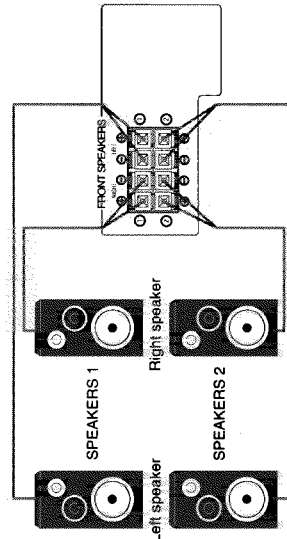

Connecting the rear and center speakers

Connect the rear speakers to the REAR SPEAKERS terminals and the center speaker to the CENTER SPEAKER terminal.

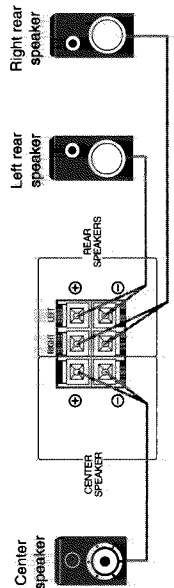

About the speaker impedance

The required speaker impedance of the front speakers differs depending on whether or not a center and/or rear speakers are connected at the same time. Since there are four possible speaker connections with the receiver, check which one fits your case and use the speaker with the impedance described below.

CASE 1 When you connect only front speakers

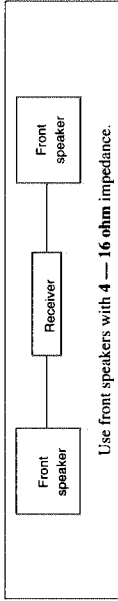

Use front speakers with 4 — 16 ohm impedance.

CASE 2 When you connect front speakers and a center speaker

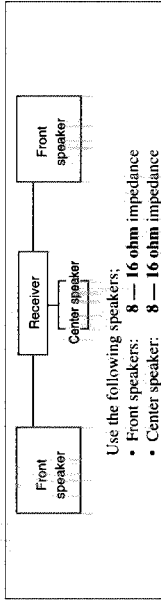

Use the following speakers:

- Front speakers: 8 — 16 ohm impedance
- Center speaker: 8 — 16 ohm impedance

CASE 3 When you connect front and rear speakers

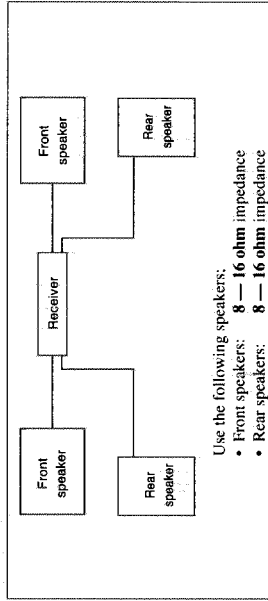

Use the following speakers:

- Front speakers: 8 — 16 ohm impedance
- Rear speakers: 8 — 16 ohm impedance

CASE 4 When you connect a center speaker as well as front and rear speakers

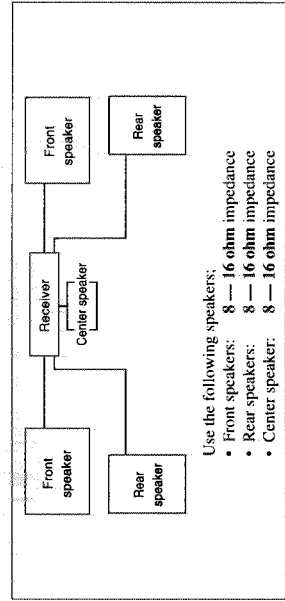

Use the following speakers:

- Front speakers: 8 — 16 ohm impedance
- Rear speakers: 8 — 16 ohm impedance
- Center speaker: 8 — 16 ohm impedance

CAUTION:

When connecting speakers, use speakers with the SAME IMPEDANCE indicated by the speaker terminals.

Notes:

- When you connect rear speakers, make sure that both left and right speakers are connected; otherwise, no sound will come out of the rear speakers.
- You can register the center speaker size after you finish its connection. If you register it, you do not have to set the center speaker mode while setting the surround mode. (If you do not use a center speaker, register that information.) See page 13.

Getting Started

Connecting Other Components

You can connect the following components to the receiver using cables with RCA pin plugs.

Audio Components	Video Components*
<ul style="list-style-type: none"> Turntable CD player Cassette deck 	<ul style="list-style-type: none"> VCR Video disc player

* You cannot connect the video input/output from the video components to this receiver.

Audio component connections

If a ground cable is provided for your turntable, connect the cable to the GND terminal of the AM LOOP terminals on the rear panel.

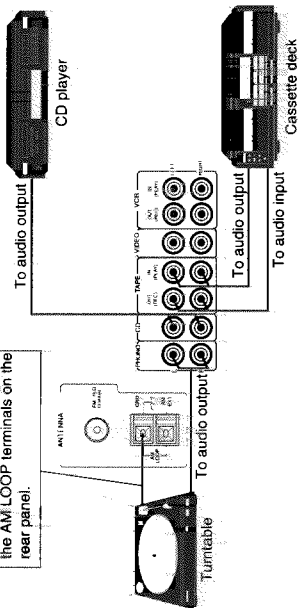

If your audio components have a COMPU LINK-3 terminals

The COMPU LINK remote control system allows you to control other JVC audio components from the receiver or vice versa. For detailed information about the COMPU LINK-3 remote control system, see page 37.

Video component connections

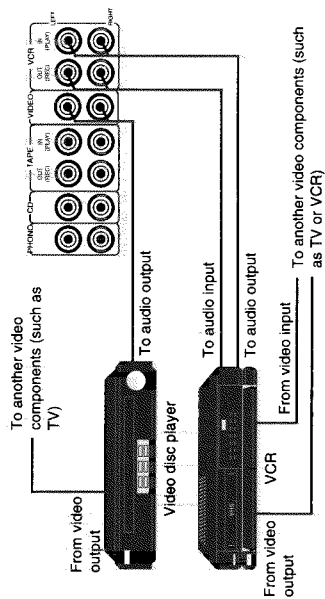

Connecting the Power Cord

Before plugging the receiver into an AC outlet, make sure that all connections have been made.

1. Plug the power cord into an AC outlet.
2. Press **POWER** to set it in the **ON** position. The STANDBY lamp lights up. A small amount of power is always consumed.

To shut off the power completely:

Press **POWER** to set it in the **OFF** position.

Keep the power cord away from the connecting cables for the TV, VCR, and antenna. The power cord may cause noise or screen interference. We recommend that you use a coaxial cable to connect the antenna, since it is well-shielded against interference.

The difference between the POWER switch and the STANDBY/ON button

- The **POWER** switch is the mains supply switch, allowing the receiver to connect to the mains supply. To shut off the power completely, press the **POWER** switch to set it in the **OFF** position.
- The **STANDBY/ON** button is a functional on/off (standby) switch, and does not disconnect the receiver from the mains supply. A small amount of power is consumed even in standby mode for receiver to accept signals from the remote control.

Putting Batteries in the Remote Control

Before using the remote control, put the two supplied batteries in first. When using the remote control, aim the remote control directly at the remote sensor on the receiver.

1. On the back of the remote control, press down on the battery cover and slide it out.
2. Insert batteries. Make sure to observe the proper polarity: (+) to (+) and (-) to (-).
3. Slide the cover.

R6P (SUM-3)/AA (15F)

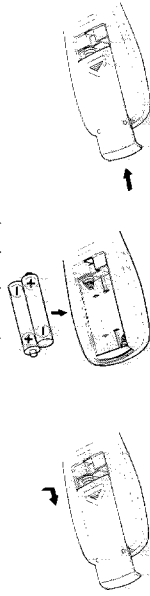

If the range or effectiveness of the remote control decreases, replace the batteries. Use two R6P (SUM-3)/AA (15F) type dry-cell batteries.

Notes:

The preset setting such as preset channel and sound adjustment may be erased in the following cases:

- When you press **POWER** to set it in the **OFF** position.
- When you unplug the power cord.
- When a power failure occurs.

CAUTIONS:

- Do not touch the power cord with wet hands.
- Do not pull on the power cord to unplug the receiver. When unplugging the receiver, always grasp the plug itself so as not to damage the cord.

CAUTIONS:

- Follow these precautions to avoid leaking or cracking cells.
- Place batteries in the remote control so they match the polarity indicated: (+) to (+) and (-) to (-).
- Use the correct type of batteries. Batteries that look similar may differ in voltage.
- Always replace both batteries at the same time.
- Do not expose batteries to heat or flame.

Basic Operations

The following operations are commonly used when you play any sound source.

Turning the Power On and Off (Standby)

On the front panel:

To turn on the power, press STANDBY/ON . The STANDBY lamp goes off. The name of the current source (or station frequency) appears on the display.

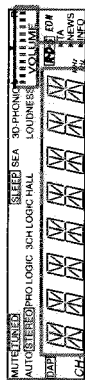

Current source name appears
Current volume level is shown here

To turn off the power (into standby mode), press STANDBY/ON again. The STANDBY lamp lights up.

From the remote control:

To turn on the power, press AUDIO.

The STANDBY lamp goes off. The name of the current source (or station frequency) appears on the display.

To turn off the power (into standby mode), press AUDIO again. The STANDBY lamp lights up.

Selecting the Source to Play

On the front panel:

- Press SOURCE so that the Control Δ / ∇ buttons work for selecting the source. The lamp above the button lights up.
- Press Control Δ / ∇ until the source name you want appears on the display.

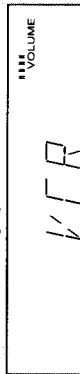

From the remote control:

Press one of the source buttons directly.

- CD* Listen to the CD player.
- TAPE* Listen to the cassette deck.
- TUNER/BAND* Listen to the radio. Each time you press the button, the band alternates between FM and AM (MW/LW).
- VCR View the playback picture from the VCR.
- VIDEO View the video component connected to the VIDEO jacks.
- PHONO* Listen to a record.



Adjusting the Volume

On the front panel:

To increase the volume, turn MASTER VOLUME clockwise.

To decrease the volume, turn it counterclockwise.

When you turn MASTER VOLUME rapidly, the volume level also changes rapidly.
When you turn MASTER VOLUME slowly, the volume level also changes slowly.

From the remote control:

To increase the volume, press VOLUME +.

To decrease the volume, press VOLUME -.

Selecting the Front Speakers

On the front panel only:

When you have connected two sets of front speakers, you can select which to use. Pressing SPEAKERS 1 or SPEAKERS 2 activates the respective set of speakers.

To use the set of speakers connected to the FRONT SPEAKERS ① terminals, press SPEAKERS 1 to set it in the --ON position, and press SPEAKERS 2 to set it in the --OFF position.

To use the set of speakers connected to the FRONT SPEAKERS ② terminals, press SPEAKERS 2 to set it in the --ON position, and press SPEAKERS 1 to set it in the --OFF position.

To use both set of speakers, press both SPEAKERS 1 and 2 to set them in the --ON position.

To use neither set of speakers, press both SPEAKERS 1 and 2 to set them in the --OFF position.

Muting the Sound

From the remote control only:

Press MUTING to turn off the sound through all speakers and headphones connected. "MUTE" appears on the display and the volume turns off.



To restore the sound, press MUTING again. Turning MASTER VOLUME or pressing VOLUME +/- also restores the sound.

CAUTION:

Always set the volume to the minimum before starting any source. If the volume is set at its high level, the sudden blast of sound energy can permanently damage your hearing and/or ruin your speakers.

Note:

The volume level can be adjusted within the range of "0" (minimum) to "62" (maximum).

Notes:

- When only one set of the front speakers is connected to either the FRONT SPEAKERS ① or ② terminals, do not press both SPEAKERS 1 and 2 to set them in the --ON position. If you do, no sound comes out of the front speakers.
- The SPEAKERS 1 and 2 do not affect the sound output of the center and rear speakers.

Basic Operations

English

Recording a Source

You can record any source playing through the receiver to a cassette deck connected to the TAPE jacks and the VCR connected to the VCR jacks at the same time. While recording, you can listen to the selected sound source at whatever sound level you like, without affecting the sound levels of the recording.

Listening with Headphones

A standard pair of headphones can be connected to the PHONES jack on the front panel. **Be sure to turn down the volume before connecting or putting on headphones, as high volume can damage both the headphones and your hearing.**

To listen with only headphones

Press both SPEAKERS 1 and 2 to set them in the **OFF** position.



Note:

The output volume level, preset SEA, DAP, 3D-PHONIC and surround modes cannot affect the recording.

Note:

The SPEAKERS 1 and 2 do not affect the sound output of the center and rear speakers.

Basic Settings

Some of the following settings are required after connecting and positioning your speakers in your listening room, while others will make operations easier.

English

Adjusting the Front Speaker Output Balance

If the sounds you hear from the front right and left speakers are unequal, you can adjust the speaker output balance.

On the front panel only:

1. Press SETTING so that the Control $\Delta / \nabla / \triangleleft / \triangleright$ buttons work for adjusting the balance.

The lamp above the button lights up.



2. Press Control Δ / ∇ until "BALANCE" appears on the display.

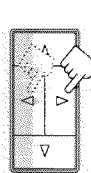

3. Press Control $\triangleleft / \triangleright$ to adjust the balance.

- Pressing Control \triangleleft decreases the right channel output.
- Pressing Control \triangleright decreases the left channel output.

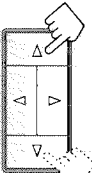

Note:

If the balance is not set at the center, "BALANCE- \triangleleft " or "BALANCE \triangleright " will appear in step 2.

Listening at Low Volume (Loudness)

Human ears are not sensitive to bass at low volume. To compensate for this, the Loudness function automatically boosts the bass level as you lower the volume.

On the front panel only:

1. Press SETTING so that the Control $\Delta / \nabla / \triangleleft / \triangleright$ buttons work for setting the Loudness function.

The lamp above the button lights up.

2. Press Control Δ / ∇ until "LOUDNESS" appears on the display.

3. Press Control $\triangleleft / \triangleright$ to set the Loudness function to "ON" or "OFF."

- Select "ON" to activate the Loudness function. The LOUDNESS indicator lights up on the display.
- Select "OFF" to cancel it. The indicator goes off.

Using the Sleep Timer

Using the Sleep Timer, you can fall asleep to music and know the receiver will turn off by itself rather than play all night.

On the front panel only:

1. Press SETTING so that the Control $\Delta / \nabla / \triangleleft / \triangleright$ buttons work for setting the Sleep Timer.

The lamp above the button lights up.

2. Press Control Δ / ∇ until "SLEEP" appears on the display.

3. Press Control $\triangleleft / \triangleright$ to set the shut-off time.

The SLEEP indicator lights up on the display.

Each time you press the button, the shut-off time on the display changes as follows:



Basic Settings

When the shut-off time comes

The receiver turns off automatically.

To check or change the time remaining until the shut-off time

1. Press **SETTING**, if necessary, so that the Control $\Delta / \nabla / \triangleleft / \triangleright$ buttons work for setting the Sleep Timer.
 2. Press Control Δ / ∇ , if necessary, until "SLEEP" appears on the display.
 3. Press Control $\triangleleft / \triangleright$.
The remaining time until the shut-off time appears in minutes.
- To change the shut-off time, press Control $\triangleleft / \triangleright$ repeatedly.

To cancel the Sleep Timer

Press Control $\triangleleft / \triangleright$ repeatedly in step 3 above until "0" appears on the display. (The SLEEP indicator goes off.)
Turning off the power also cancels the Sleep Timer.

Selecting the Center Speaker Size

You can register the information about the center speaker after all connections are completed.

If you do this registration first, you do not have to adjust the center speaker mode when you want to activate the surround sound.

On the front panel only:

1. Press **SETTING** so that the Control $\Delta / \nabla / \triangleleft / \triangleright$ buttons work for selecting the center speaker size.
The lamp above the button lights up.
2. Press Control Δ / ∇ until "CNTR SPK" (Center Speaker) appears on the display.
3. Press Control $\triangleleft / \triangleright$ to select the appropriate item about your center speaker.
Each time you press the button, the display changes to show the following:

SMALL \longleftrightarrow LARGE \longleftrightarrow NO \longleftrightarrow

SMALL:	Select this mode when the size of the center speaker is smaller than that of the front speakers.
LARGE:	Select this mode when the size of the center speaker is the same as that of the front speakers.
NO:	Select this mode when you do not use a center speaker.

One Touch Operation

This receiver can memorize the optimum sound settings for each playing source.

About the One Touch Operation

JVC's One Touch Operation function is used to assign and store different sound settings for each different playing source. By using this function, you do not have to change the settings every time you change the source. The stored settings for the newly selected source are automatically recalled.

The following can be stored for each source:

- Volume level (see page 10)
- Balance (see page 12)
- Loudness (see page 12)
- Preset SEA modes (see page 24)
- 3D-PHONIC mode settings (see page 27)
- DAP mode settings (see page 29)
- Surround mode settings (see page 36)

Using the One Touch Operation

To store the sound settings

1. Press **ONE TOUCH OPERATION**.
The ONE TOUCH OPERATION lamp lights up, then the previously memorized settings are recalled and appear on the display in turn.

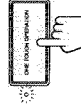

2. Adjust the sound using the functions listed above.
The newly adjusted settings are memorized.

To recall the sound settings

With the ONE TOUCH OPERATION lamp lit, the settings for the currently selected source is recalled, and appears on the display when the source is selected.



To cancel the One Touch Operation function

Press **ONE TOUCH OPERATION** so that the lamp goes off.
(Even though the One Touch Operation function is canceled, the recalled sound effects remain active.)

Note:

- If the source is **TUNER/BAND**, the One Touch Operation function memorizes the settings each for the **FM and AM band**.
- The **DAP mode, surround mode and 3D-PHONIC mode** cannot be used at the same time.

Receiving Radio Broadcasts

You can browse through all the stations or use the preset function to go immediately to a particular station.

Tuning in Stations Manually

On the front panel only:

1. Press TUNER/BAND. The indicator above the button lights up. Each time you press the button, the band alternates between FM and AM (MW/LW).
2. Press Control Δ / ∇ until "TUNING+" appears on the display.
3. Press Control Δ / ∇ until you find the frequency you want.
 - Pressing Control Δ decreases the frequency.
 - Pressing Control ∇ increases the frequency.

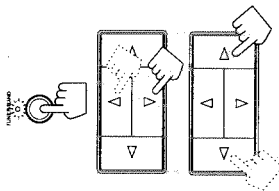

Using Preset Tuning

Once a station is assigned to a channel number, the station can be quickly tuned. You can preset up to 40 stations at random.

To store the preset stations

On the front panel only:

1. Tune in the station you want to preset (see above). If you want to store the FM reception mode for this station, select the FM reception mode you want. See page 17 for details.
2. Press MEMORY. The channel number starts flashing on the display for about 5 seconds.
3. Press Control Δ / ∇ to select a channel number while the channel number position is flashing.
 - Pressing Control Δ decreases the number.
 - Pressing Control ∇ increases the number.
4. Press MEMORY again while the selected channel number is flashing on the display. The selected channel number stops flashing. The station is assigned to the selected channel number.

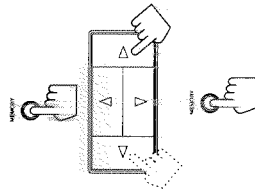

Notes:

- When you hold down Control Δ / ∇ in step 3, the frequency keeps changing until you press Control Δ / ∇ again or a station is tuned in.
- When a station of sufficient signal strength is tuned in, the TUNED indicator lights up on the display. When an FM stereo program is received, the STEREO indicator also lights up.

CAUTION:

- The preset channels may be erased in the following cases:
- When you press Ⓚ POWER to set it in the ■ OFF position.
 - When you unplug the power cord.
 - When a power failure occurs.

Note:

You can press 10 keys on the remote control to select a channel number in step 3, if you have pressed TUNER/BAND on the remote control prior to starting this preset procedure.

- For channel number 5, press 5 +10 then 5.
- For channel number 20, press +10 then 10.
- For channel number 30, press +10, +10, then 10.

5. Repeat steps 1 to 4 until you store all the stations you want.

To cancel a stored preset station

Storing a new station on a used number erases the previously stored one.

To tune in a preset station

On the front panel:

1. Press TUNER/BAND so that the Control Δ / ∇ / Δ / ∇ buttons work for tuner settings. The lamp above the button lights up.
2. Press Control Δ / ∇ until "PRESET+" appears on the display.
3. Press Control Δ / ∇ to select a preset channel. Each time you press the button, the preset channels change.
 - Pressing Control Δ changes preset channels in decreasing order.
 - Pressing Control ∇ changes preset channels in increasing order.

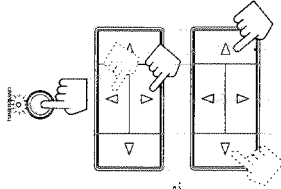

From the remote control:

1. Press TUNER/BAND. Each time you press the button, the band alternates between FM and AM (MW/LW).
2. Press 10 keys to select a preset channel number.
 - For channel number 5, press 5.
 - For channel number 15, press +10 then 5.
 - For channel number 20, press +10 then 10.
 - For channel number 30, press +10, +10, then 10.

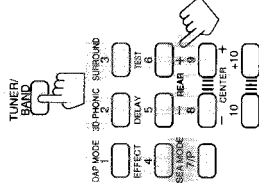

Note:

If you adjust the sound by using SOUND CONTROL while listening to a station, the 10 keys will work for adjusting the sound. To select a preset channel number after the sound adjustment, press TUNER/BAND again, so the 10 keys will work for selecting the preset channel numbers.

Receiving Radio Broadcasts

Selecting the FM Reception Mode

You can change the FM reception mode while receiving an FM broadcast.

On the front panel only:

1. Press **TUNER/BAND** so that the Control Δ / ∇ / \triangleleft / \triangleright buttons work for tuner settings.
The lamp above the button lights up.
2. Press Control Δ / ∇ until "FM MODE" appears on the display.
3. Press Control \triangleleft / \triangleright to select either "FM AUTO" or "FM MONO."
 - Normally select "FM AUTO."
 - When an FM stereo broadcast is hard to receive or noisy, select "FM MONO."

Note:
You can store the FM reception mode for each preset station.

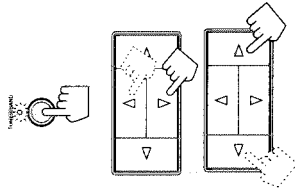

FM AUTO:	When a program is broadcast in stereo, you will hear stereo sound; when in monaural, you will hear monaural sounds. This mode is also useful to suppress static noise between stations. The MUTE AUTO indicator lights up on the display.
FM MONO:	Reception will be improved although you will lose the stereo effect. In this mode, you will hear noise while tuning into the stations. The MUTE AUTO indicator goes off on the display.

Using the RDS (Radio Data System) to Receive FM Stations

RDS allows FM stations to send an additional signal along with their regular program signals. For example, the stations send their station names, as well as information about what type of program they broadcast, such as sports or music, etc.

When tuned to an FM station which provides the RDS service, the RDS indicator lights up on the display.

With the receiver, you can receive the following types of RDS signals.

- PS (Program Service) : shows commonly known station names
- PTY (Program Type) : shows types of broadcast programs
- RT (Radio Text) : shows text messages the station sends
- EON (Enhanced Other Network) : see page 22.

Note:
RDS may not operate correctly if the station tuned is not transmitting RDS signal properly or if the signal strength is weak.

About characters shown on the display

When the display shows PS, PTY, or RT signals, the following characters are used.

- The display cannot differentiate upper case and lower case letters and always uses upper case letters.
- The display cannot show accented letters, "À", for instance, may stand for accented "As," like "Á, Â, Ã, Ä, Å, and Ä."

A	À	Á	Â	Ã	Ä	Å	Ä	0	1	2	3	4	5	6	7	8	9
B	À	Á	Â	Ã	Ä	Å	Ä	0	1	2	3	4	5	6	7	8	9
C	À	Á	Â	Ã	Ä	Å	Ä	0	1	2	3	4	5	6	7	8	9
D	À	Á	Â	Ã	Ä	Å	Ä	0	1	2	3	4	5	6	7	8	9
E	À	Á	Â	Ã	Ä	Å	Ä	0	1	2	3	4	5	6	7	8	9
F	À	Á	Â	Ã	Ä	Å	Ä	0	1	2	3	4	5	6	7	8	9
G	À	Á	Â	Ã	Ä	Å	Ä	0	1	2	3	4	5	6	7	8	9
H	À	Á	Â	Ã	Ä	Å	Ä	0	1	2	3	4	5	6	7	8	9
I	À	Á	Â	Ã	Ä	Å	Ä	0	1	2	3	4	5	6	7	8	9
J	À	Á	Â	Ã	Ä	Å	Ä	0	1	2	3	4	5	6	7	8	9

What Information Can RDS Signals Provide?

You can see the RDS signals the station sends on the display.

To show the RDS signals

Press DISPLAY MODE while listening to an FM station.

Each time you press the button, the display changes to show you the following information:

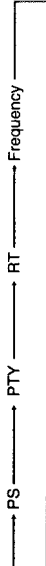

PS (Program Service):

While searching, "PS" appears and then the station names will be displayed.

"NO PS" appears if no signal is sent.

PTY (Program Type):

While searching, "PTY" appears and then the type of the broadcast program will be displayed. "NO PTY" appears if no signal is sent.

RT (Radio Text):

While searching, "RT" appears and then text messages the station sends will be displayed. "NO RT" appears if no signal is sent.

Station Frequency:

Station frequency (non-RDS service)

When pressing DISPLAY on the remote control:

Make sure that you have selected FM station using the remote control.

If not, the DISPLAY button does not work for tuner operation. (Pressing TUNER/BAND activates the remote control for tuner operation.)

Notes:

- If searching finishes at once, "PS", "PTY", and "RT" will not appear on the display.
- Even if you press DISPLAY MODE (or DISPLAY) while listening to an AM (MW/LW) station, the display only shows station frequency.
- RDS is not available for AM (MW/LW) broadcasts.

Receiving Radio Broadcasts

Searching for a Program by PTY Codes

One of the advantages of the RDS service is that you can locate a particular kind of program from the preset channels by specifying the PTY codes.

To search for a program using the PTY codes

1. Press **PTY SEARCH** while listening to an FM station so that Control $\triangleleft/\triangleright$ buttons work for selecting PTY code.

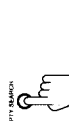

"PTY" and "SELECT" alternate on the display.

2. Press Control $\triangleleft/\triangleright$ until the PTY code you want appears on the display. Each time you press the button, the display gives you the PTY codes described on page 21.

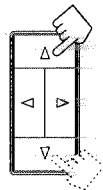

3. Press **PTY SEARCH** again. While searching, "SEARCH" and the selected PTY code alternate on the display. The receiver searches 40 preset channels, stops when it finds the one you have selected, and tunes in that station.



To continue searching after the first stop:
Press **PTY SEARCH** again while the indications on the display are flashing. If no program is found, "NOTFOUND" appears on the display.



To stop searching any time during the process:
Press **PTY SEARCH** while searching.

From the remote control:

Before starting the procedure below, make sure you have selected FM station only using the remote control. If not, the following RDS operating buttons do not work for tuner operation. (Pressing **TUNER/BAND** activates the remote control for tuner operation.)

1. Press **PTY SEARCH** while listening to an FM station. "PTY" and "SELECT" alternate on the display.
2. Press **PTY SELECT +/-** until the PTY code you want appears on the display. The display gives you the PTY codes described on page 21.



3. Press **PTY SEARCH** again. While searching, "SEARCH" and the selected PTY code alternate on the display. The receiver searches 40 preset channels, stops when it finds the one you have selected, and tunes in that station.



To continue searching after the first stop:
Press **PTY SEARCH** again while the indications on the display are flashing. If no program is found, "NOTFOUND" appears on the display.



To stop searching any time during the process:
Press **PTY SEARCH** while searching.

Receiving Radio Broadcasts

Descriptions of the PTY codes:

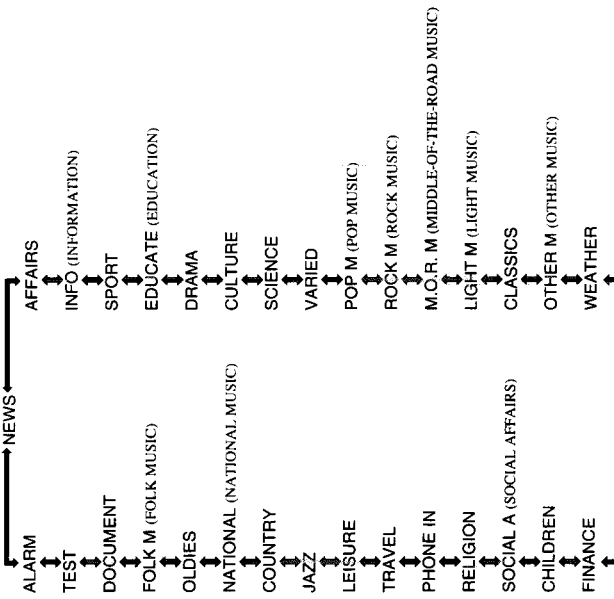

Note:
When selecting the PTY codes,
NEWS always appears first.

When an emergency broadcast (ALARM signal) is sent from an FM station:
The receiver automatically tunes in the station except in the following cases:

- When you are listening to non-RDS stations (all AM — MW/LW and some FM stations).
- When the receiver is in standby mode.

While receiving an emergency broadcast, "ALARM" appears on the display.

The TEST signal is used for equipment test — whether it can receive the ALARM signal correctly.
The TEST signal makes the receiver work in the same way as the ALARM signal does. If an TEST signal is received, the receiver automatically switches to the station broadcasting the TEST signal. While receiving an test signal, "TEST" appears on the display.

Switching to a Broadcast Program of Your Choice Temporarily
Another convenient RDS service is called "EON (Enhanced Other Network)." The EON indicator lights up while receiving a station with the EON code. This allows the receiver to switch temporarily to a broadcast program of your choice (NEWS, TA, and/or INFO) from a different station except in the following cases:

- When you are listening to a non-RDS stations (all AM — MW/LW and some FM stations).
- When the last received FM station is a non-RDS station.
- When the receiver is in standby mode.

On the front panel only:

1. Press EON so that the last selected program type appears on the display.
The receiver enters EON standby mode*.
2. Press TA/NEWS/INFO until the program type you want appears on the display.
Each time you press the button, the display changes to show the following.

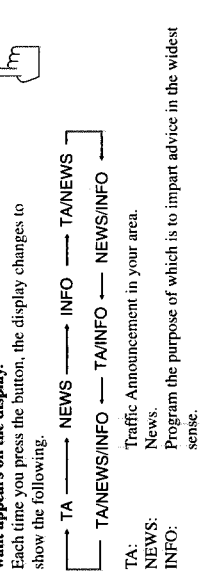

Note:
* When the receiver is in EON standby mode, the receiver is ready to receive the EON data (TA/NEWS/INFO) you select.

Continued to the next page.

Receiving Radio Broadcasts

CASE 1 If there is no station broadcasting the program you have selected

The receiver continues playing the current source (all sources except AM).



When a station starts broadcasting the program you have selected, the receiver automatically switches to the station. The indicator of received PTY code starts flashing.



When the program is over, the receiver goes back to the previously selected source, but still remains in EON standby mode. The indicator of received PTY code stops flashing and remains lit.

CASE 2 If there is a station broadcasting the program you have selected

The receiver changes the source (all sources except AM), and tunes in the station. The indicator of received PTY code starts flashing.



When the program is over, the receiver goes back to the previously selected source, but still remains in EON standby mode. The indicator of received PTY code stops flashing and remains lit.

CASE 3 If the FM station you are listening is broadcasting the program you have selected

The receiver continues to receive the station but the indicator of received PTY code starts flashing.



When the program is over, the indicator of received PTY code stops flashing and remains lit, but the receiver remains in EON standby mode.

To stop listening to the program selected by EON:

Press EON so that the program type (TA/NEWS/INFO) goes off from the display. The receiver enters EON off mode and goes back to the previously selected source. Each time you press EON, the EON mode alternates between standby mode and off mode.



Notes:

- EON data sent from some stations may not be compatible with this receiver.
- In EON standby mode, if you change the source to AM (MW/LW) or if you carry out synchronized recording (see page 37), EON standby mode is canceled temporarily. The receiver goes back to EON standby mode again when you have finished that operation.
- While listening to a program tuned in by the EON function, you can only use STANDBY/ON (on the front panel) and AUDIO (on the remote control).
- When the receiver is turned off (into standby mode), the EON function is also turned off.

CAUTION:

When the source alternates intermittently between the station tuned in by the EON function and the currently selected source, press EON to cancel the EON function. This is not a malfunction of the receiver.

Using the Preset SEA Modes

The preset SEA (Sound Effect Amplifier) modes give you control of the way your music sounds.

Selecting Your Favorite SEA Mode

On the front panel:

- Press **PRESET SEA** so that the Control $\Delta / \nabla / \triangleleft / \triangleright$ buttons work for preset SEA setting. The lamp above the button lights up.

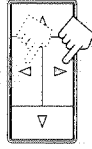

- Press Control Δ / ∇ until the preset SEA mode you want appears on the display. The SEA indicator also lights up on the display. Each time you press the button, the preset SEA modes change as follows:

Movie \leftrightarrow Sports \leftrightarrow Music \leftrightarrow OFF

- Press Control $\triangleleft / \triangleright$ to select the effect level. Each time you press the button, the effect level changes as follows:

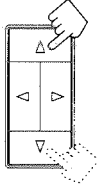

When "Movie" is selected:

MOVIE 1 \leftrightarrow MOVIE 2 \leftrightarrow MOVIE 3

When "Sports" is selected:

SPORTS1 \leftrightarrow SPORTS2 \leftrightarrow SPORTS3

When "Music" is selected:

JAZZ 1 \leftrightarrow JAZZ 2 \leftrightarrow ROCK 1 \leftrightarrow ROCK 2 \leftrightarrow COUNTRY2 \leftrightarrow COUNTRY1 \leftrightarrow MUSICAL2 \leftrightarrow MUSICAL1

Movie:	Adds breadth to sounds so you feel like you are in a movie theater.
Sports:	Makes sounds exciting.
Music:	Select one of the modes below.
JAZZ:	Gives a feeling of a live atmosphere. Good for acoustic music.
ROCK:	Gives a heavy sound. Both high and low frequencies are boosted.
MUSICAL:	Enhances the mid-frequency range, which the human voice is mostly made up of.
COUNTRY:	Enhances the high-frequency range so that instruments such as the violin and banjo are emphasized.
OFF:	No preset SEA mode is applied (See below).

To cancel the preset SEA mode

Select "OFF" in step 2 above. The SEA indicator goes off from the display.

- Notes:**
- The preset SEA modes cannot be used for recording.
 - When you turn on the preset SEA mode, the mode with its effect level previously selected is recalled at first.

Using the Preset SEA Modes

From the remote control:

1. Press **SOUND CONTROL**, so that **10 keys work for adjusting the sound.**
2. Press **SEA MODE** until the preset SEA mode you want appears on the display.
The previously selected mode is recalled (at its previous effect level) and is shown on the display.
Each time you press the button, the preset SEA modes change as follows:

Music → Sports → Movie

OFF

3. Press **SEA PRESET** to select the effect level.
Each time you press the button, the effect level changes as follows:

When "Music" is selected:
JAZZ 1 → JAZZ 2 → ROCK 1 → ROCK 2
COUNTRY2 → COUNTRY1 → MUSICAL2 → MUSICAL1

When "Sports" is selected:
SPORTS1 → SPORTS2 → SPORTS3

When "Movie" is selected:
MOVIE 1 → MOVIE 2 → MOVIE 3

To cancel the preset SEA mode

Selecting "OFF" in step 2 above.
The SEA indicator goes off from the display.



Activating the Surround Sounds

The built-in surround processor provides three groups of programs — JVC 3D-PHONIC mode, DAP (Digital Acoustic Processor) mode, and surround modes (Dolby Surround and JVC Theater Surround). You cannot use the DAP mode and surround mode at the same time. When you turn on the DAP mode, the surround mode is turned off (if it has been on), and vice versa.

On JVC 3D-PHONIC mode

JVC 3D-PHONIC mode gives you such a nearly surround effect as it is reproduced through the Dolby Surround decoder, which is widely used to reproduce sounds with a feeling of movement like those experienced in movie theaters. JVC 3D-PHONIC mode is the result of research on sound localization technology carried out at JVC for many years and makes it possible to reproduce the surround sound with only two front speakers.

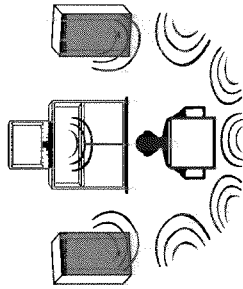

Notes:

- The surround processor has no effect on monaural sources.
- The surround processor cannot be used for recording.

On the DAP mode

The sound heard in a concert hall or club consists of direct sound and indirect sound — early reflections, and reflections from behind. Direct sounds reach the listener directly without any reflection. On the other hand, indirect sounds are delayed by the distances of the ceiling and walls. These direct sounds and indirect sounds are the most important elements of the acoustic surround effects. The DAP mode can create these important elements, and gives you a real "being there" feeling by using the front speakers and rear speakers.

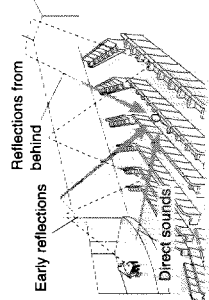

On surround modes

With this receiver, you can use two types of the surround mode.

Dolby Surround

Dolby Surround has been developed to reproduce the important elements of the acoustic surround at home.

To watch the soundtracks of video software bearing the mark  * which includes the same encoded surround information as found in Dolby Stereo films, the receiver can provide you with 2 Dolby Surround modes (Dolby Pro Logic and Dolby 3ch Logic).

Dolby Pro Logic: Select this mode when optional center and rear speakers are connected.

Dolby 3ch Logic: Select this mode when a center speaker is connected without rear speakers.

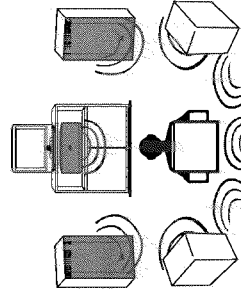

JVC Theater Surround

In order to reproduce a more realistic sound field in your listening room while playing soundtracks of video software bearing the mark , JVC Theater Surround has been designed to give you clear vocals and to create a real "being there" feeling. The sound is reproduced through the front speakers, rear speakers and center speakers.

* Manufactured under license from Dolby Laboratories Licensing Corporation. "Dolby," the double-D symbol and "Pro Logic" are trademarks of Dolby Laboratories Licensing Corporation.

Activating the Surround Sounds

Using JVC 3D-PHONIC Modes

When using JVC 3D-PHONIC modes, you need only two front speakers to reproduce the soundtracks of video software bearing the mark . The 3D-PHONIC modes give you very realistic surround effects as if the sound is reproduced through the Dolby Surround decoder.

On the front panel:

1. Press SURROUND so that the Control $\Delta / \nabla / \triangleleft / \triangleright$ buttons work for selecting the surround/DAP/3D-PHONIC modes.
The lamp above the button lights up.



2. Press Control Δ / ∇ until one of the 3D-PHONIC mode ("3DACTION", "3DTHEATR", or "3DDRAMA") appears on the display.
Each time you press the button, surround/DAP/3D-PHONIC modes change as follows:



* As for the DAP modes (see page 29) and the 3D-PHONIC modes, one of the previously selected mode appears on the display.

3. Press Control $\triangleleft / \triangleright$ until the 3D-PHONIC mode you want appears on the display.
Each time you press the button, the 3D-PHONIC modes change as follows:

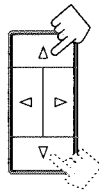

3DACTION	Best for action and war movies — where the action is fast and explosive.
3DTHEATR	Reproduces the sound field of a large theater.
3DDRAMA	Best for dramas and romantic movies — where the action is slow and soft.

4. Press ADJUST so that Control Δ / ∇ buttons work for adjusting the effect level.
The lamp above the button lights up.



5. Press Control Δ / ∇ until "EFFECT+" appears on the display.

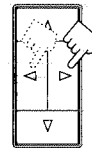

Note:

The 3D-PHONIC mode is not used with other surround modes such as Dolby Surround, JVC Theater Surround and the DAP modes. When the 3D-PHONIC mode is turned on, the other surround mode, if used, will be turned off.

Note:

When one of the 3D-PHONIC modes is selected, the 3D-PHONIC indicator also lights up on the display.

Note:

Once you have adjusted the effect level, it is memorized for each 3D-PHONIC mode.

6. Press Control $\triangleleft / \triangleright$ to adjust the effect level.
Each time you press the button, the effect level changes as follows:

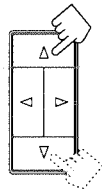

As the number increases, the effect of the selected 3D-PHONIC mode becomes stronger.

7. Select and play a sound source which was processed with Dolby Surround and is labeled with  mark.

To cancel the 3D-PHONIC mode

Select "OFF" in step 2.
The 3D-PHONIC indicator goes off from the display.

From the remote control:

1. Press SOUND CONTROL so that 10 keys work for adjusting the sound.



2. Press 3D-PHONIC to select the 3D-PHONIC mode you want.
The previously selected mode is recalled at first (at its previous effect level) and is shown on the display.
The 3D-PHONIC indicator also lights up on the display.
Each time you press the button, the 3D-PHONIC modes change as follows:

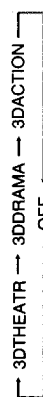

3. Press EFFECT to select the effect level.
Each time you press the button, the level changes as follows:

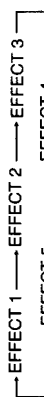

As the number increases, the effect of the selected 3D-PHONIC mode becomes stronger.

4. Select and play a sound source which was processed with Dolby Surround and is labeled with  mark.

To cancel the 3D-PHONIC mode

Select "OFF" in step 2 above.
The 3D-PHONIC indicator goes off from the display.

Note:

Once you have adjusted the effect level, it is memorized for each 3D-PHONIC mode.

Activating the Surround Sounds

Using the DAP Modes

You can use five DAP modes — "Dance Club, Live Club, Hall, Pavilion, and Headphones." These modes (except "Headphones") require the front speakers and the rear speakers, but do not require a center speaker to enlarge the sound field.

Among the DAP modes, "Headphones" is very special. It can create the same stereo sound as you listen through the speakers off air while listening to a source using headphones. So, you can feel as if you were not using the headphones and listening to music in a room.

On the front panel:

1. Press SURROUND so that the Control $\Delta / \nabla / \triangleleft / \triangleright$ buttons work for selecting the surround/DAP/3D-**PHONIC** modes.
The lamp above the button lights up.



2. Press Control Δ / ∇ until one of the DAP mode ("HEAD P", "PAVILION", "HALL", "LIVE C", or "DANCE C") appears on the display.
Each time you press the button, the surround/DAP/3D-**PHONIC** modes change as follows:

Ex: PROLOGIC \leftrightarrow THEATER \leftrightarrow 3CHLOGIC \leftrightarrow PAVILION*
(One of the five modes appears)

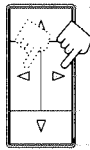

* As for the 3D-**PHONIC** modes (see page 27) and the DAP modes, one of the previously selected mode appears on the display.

3. Press Control $\triangleleft / \triangleright$ until the DAP mode you want appears on the display.
Each time you press the button, the DAP modes change as follows:

HEAD P \leftrightarrow PAVILION \leftrightarrow HALL
DANCE C \leftrightarrow LIVE C \leftrightarrow HALL

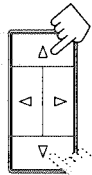

HEAD Phones*	Gives a spacious stereo effect when listening with headphones.
PAVILION	Gives the spacious feeling of a pavilion with a high ceiling.
HALL	Gives clear vocal and the feeling of a concert hall.
LIVE Club	Gives the feeling of a live music club with a low ceiling.
DANCE Club	Gives a throbbing bass beat.

* When you select "HEAD P", you cannot go to the following steps. No adjustments can be made for "Headphones."



4. Press ADJUST so that the Control $\Delta / \nabla / \triangleleft / \triangleright$ buttons work for adjusting the selected mode.
The lamp above the button lights up.

5. Press Control Δ / ∇ until "REAR +" appears on the display.

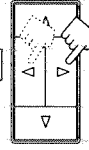

Note:
Once you have adjusted the DAP modes, the adjustment is memorized for each DAP mode.

6. Press Control $\triangleleft / \triangleright$ to adjust the rear speaker output level.
 - Pressing Control \triangleleft decreases the output level up to -10 dB.
 - Pressing Control \triangleright increases the output level up to +10 dB.

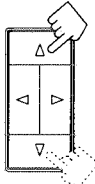

7. Press Control Δ / ∇ until "EFFECT +" appears on the display.

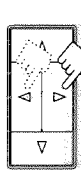

8. Press Control $\triangleleft / \triangleright$ to adjust the effect level.
Each time you press the button, the effect level changes as follows:

EFFECT 1 \leftrightarrow EFFECT 2 \leftrightarrow EFFECT 3 \leftrightarrow EFFECT 4 \leftrightarrow EFFECT 5

Note:

When adjusting the effect level for "PAVILION" or "HALL," a reverb sound comes out. This is because a long reverb is applied to these two modes.

As the number increases, the effect of the selected DAP mode becomes stronger.

To cancel the DAP mode

Select "OFF" in step 2.
The DAP indicator goes off from the display.

From the remote control:

1. Press **SOUND CONTROL** so that 10 keys work for adjusting the sound.



2. Press **DAP MODE** to select the DAP mode you want.

The previously selected mode is recalled at first (at its previous effect level) and is shown on the display. The DAP indicator also lights up on the display.

Each time you press the button, the DAP modes change as follows:

HEAD P \leftrightarrow PAVILION \leftrightarrow HALL
OFF \leftrightarrow DANCE C \leftrightarrow LIVE C



* When you select "HEAD P" (or "OFF"), you cannot go to the following steps. No adjustments can be made for "Headphones."

3. Press **REAR +/-** to adjust the rear speaker output level.
 - Pressing **REAR -** decreases the output level up to -10 dB.
 - Pressing **REAR +** increases the output level up to +10 dB.



4. Press **EFFECT** to select the effect level.
Each time you press the button, the effect level changes as follows:

EFFECT 1 \leftrightarrow EFFECT 2 \leftrightarrow EFFECT 3 \leftrightarrow EFFECT 4 \leftrightarrow EFFECT 5



To cancel the DAP mode

Select "OFF" in step 2 above.
The DAP indicator goes off from the display.

Activating the Surround Sounds

With this receiver, you can use two types of the surround modes — Dolby Surround and JVC Theater Surround.

Speaker Arrangements for Surround Modes

The following illustrations show how to obtain the optimum sound environment for various surround modes settings. Try to find the speaker direction and location to create the optimum sound field.

CASE 1 When you have added a center speaker and rear speakers

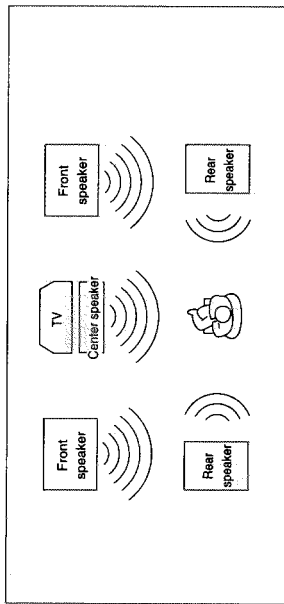

CASE 2 When you have added rear speakers (without a center speaker)

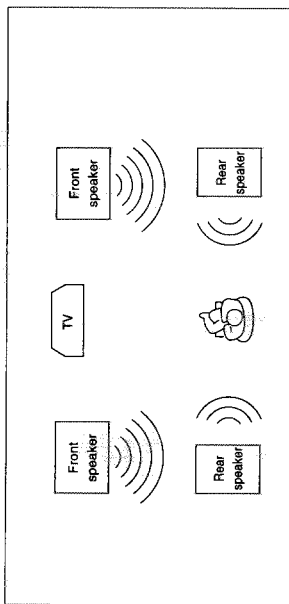

CASE 3 When you have added a center speaker (without rear speakers)

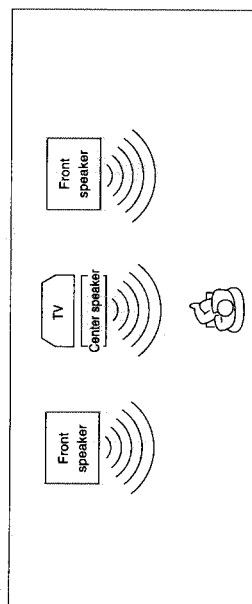

Preparing for Surround Modes

Once you have set the surround modes, you can use the same adjustment every time you want to activate the surround mode you want. The receiver memorizes surround adjustments for each mode.

On the front panel:

1. Press SURROUND so that the Control Δ / ∇ buttons work for selecting the surround modes. The lamp above the button lights up.
2. Press CONTROL Δ / ∇ to select one of the surround mode ("PROLOGIC", "3CHLOGIC", or "THEATER"). Each time you press the button, the surround modes change as follows:



PROLOGIC	Select this mode when you use a center speaker and rear speakers.
THEATER	Select this mode to watch a video source with Dolby Surround when you have connected the rear speakers (and a center speaker). This mode gives you the feeling of a movie theater.
3CHLOGIC	Select this mode when you use a center speaker without rear speakers.
OFF	Select this to turn off the surround/DAP/3D-PHONIC modes.

* You cannot select the 3D-PHONIC modes or the DAP modes in this step. For the 3D-PHONIC modes: see pages 27 and 28. For the DAP modes: see pages 29 and 30.

3. Press ADJUST so that the Control $\Delta / \nabla / \triangleleft / \triangleright$ buttons work for adjusting the selected surround mode. The lamp above the button lights up.

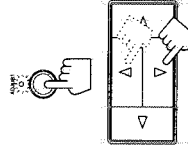

4. Press Control Δ / ∇ until "CNT MODE" (Center Mode) appears on the display.

Continued to the next page.

Note:
When one of the surround modes is selected, the corresponding indicator lights up on the display.

Note:
If you have already set the center speaker size following the procedure described on page 13, you do not have to select the center mode in this procedure.

In this case:
1. Select "PROLOGIC" or "THEATER."
2. Select "NORMAL" or "WIDE" for center mode.
See pages 32 to 35 for more details.

In this case:
1. Select "PROLOGIC" or "THEATER."
2. Select "PHANTOM" for center mode.
See pages 32 to 35 for more details.

In this case:
1. Select "3CHLOGIC."
2. Select "NORMAL" or "WIDE" for center mode.
See pages 32 to 35 for more details.

Activating the Surround Sounds

5. Press Control $\triangleleft/\triangleright$ to select the center mode.

Each time you press the button, the center modes change as follows:

WIDE \rightarrow NORMAL \rightarrow PHANTOM

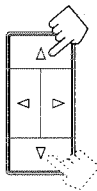

WIDE	Select this mode when the center speaker can reproduce the bass better than the front speakers. All signals of the center channel are output through the center speaker.
NORMAL	Select this mode when the center speaker cannot reproduce the bass better than the front speakers. The bass portions of the center channel signals are output through the front speakers.
PHANTOM	Select this mode when you do not use a center speaker. The center speaker channel signals are output through the front speakers.

6. Press Control \triangle/\triangleright until "--DELAY +" appears on the display.

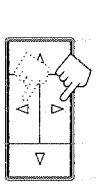

7. Press Control $\triangleleft/\triangleright$ to adjust the delay time of the rear speaker output.

Each time you press the button, the delay time changes as follows:

DELAY 1 \rightarrow DELAY 2 \rightarrow DELAY 3

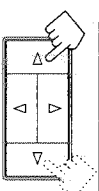

DELAY 1	Select this when the distance from you to your rear speakers is greater than that to the front speakers.
DELAY 2	Select this when the distance from you to your rear speakers is almost equal to that to the front speakers.
DELAY 3	Select this when the distance from you to your rear speakers is less than that to the front speakers.

8. Press Control \triangle/\triangleright until "TEST" appears on the display, then press Control $\triangleleft/\triangleright$ to start checking the speaker output balance.

"TEST" starts flashing on the display, and a test tone comes out of the speakers in the following order:

Left front speaker \rightarrow Center speaker \rightarrow Right front speaker \rightarrow Rear speakers

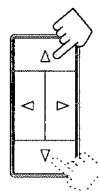
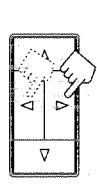

9. If necessary, adjust the speaker output balance as follows:

- To adjust the rear speaker output level, press Control \triangle/\triangleright until "--REAR +" appears on the display, then press Control $\triangleleft/\triangleright$.

- To adjust the center speaker output level, press Control \triangle/\triangleright until "--CENTER+" appears on the display, then press Control $\triangleleft/\triangleright$.

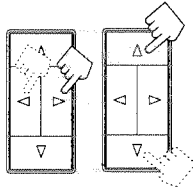

10. Press Control \triangle/\triangleright until "TEST" appears on the display, then press Control $\triangleleft/\triangleright$ twice to stop the test tone.

If you have selected JVC Theater Surround, go to the following steps.

11. Press Control \triangle/\triangleright until "--EFFECT+" appears on the display.

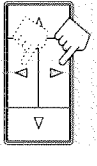

12. Press Control $\triangleleft/\triangleright$ to adjust the effect level.

Each time you press the button, the effect level changes as follows:

EFFECT 1 \rightarrow EFFECT 2 \rightarrow EFFECT 3 \rightarrow EFFECT 4 \rightarrow EFFECT 5

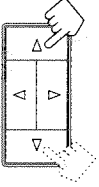

As the number increases, the effect of the Theater Surround mode becomes stronger.

From the remote control:

If you have already set the center speaker size following the procedure described on page 13, you can use the remote control for surround mode preparation.

1. Press SOUND CONTROL so that 10 keys work for adjusting the sound.



2. Press SURROUND until the surround mode you want appears on the display.

The previous mode is recalled (with its previous settings) and is shown on the display.

The indicator for that mode also lights up on the display. Each time you press the button, the surround modes change as follows:

THEATER \rightarrow 3CHLOGIC \rightarrow PROLOGIC \rightarrow OFF



3. Press DELAY to adjust the delay time of the rear speaker output.

Each time you press the button, the delay time changes as follows:

DELAY 1 \rightarrow DELAY 2 \rightarrow DELAY 3



Notes:

- The sound levels of the left and right rear speakers will be the same.
- You cannot set the sound level of the rear speakers when you have selected "3CHLOGIC."
- You cannot set the sound level of the center speaker when you select "PHANTOM" for the center mode.

Note:

When you have selected "PROLOGIC" or "3CHLOGIC," you cannot select the effect level.

Note:

When you have selected "3CHLOGIC" or "THEATER," you cannot adjust the delay time.

Continued to the next page.

1-24

English

Activating the Surround Sounds

4. Press **TEST** to start checking the speaker output balance.

"TEST" starts flashing on the display, and a test tone comes out of the speakers in the following order:

5. If necessary, adjust the speaker output balance as follows:

- To adjust the rear speaker output level, press **REAR +/-**.
- To adjust the center speaker output level, press **CENTER +/-**.

Pressing - decreases the output level up to -10 dB.
Pressing + increases the output level up to +10 dB.

6. Press **TEST** again to stop the test tone.

If you have selected JVC Theater Surround, go to the following steps.

7. Press **EFFECT** to adjust the effect level.

Each time you press the button, the effect level changes as follows:

As the number increases, the effect of the Theater Surround mode becomes stronger.

Note:

When you have selected "PROLOGIC" or "3CHLOGIC," you cannot select the effect level.

Note:

When you have selected "PROLOGIC" or "3CHLOGIC," you cannot select the effect level.

Notes:

- No test tone comes out of the rear speakers when you have selected "3CHLOGIC."
- No test tone comes out of the center speaker when you select "PHANTOM" for the center mode.

Notes:

- The sound levels of the left and right rear speakers will be the same.
- You cannot set the sound level of the rear speakers when you have selected "3CHLOGIC."
- You cannot set the sound level of the center speaker when you select "PHANTOM" for the center mode.

English

RX554RBK

Using Surround Modes

Once you have adjusted the surround mode, you can use the same adjustments every time you want to enjoy Surround Modes.

From the front panel:

1. Press **SURROUND** so that the Control Δ/∇ buttons work for selecting the surround/DAP/3D-PHONIC modes.

The lamp above the button lights up.

2. Press Control Δ/∇ to select one of the surround mode ("PROLOGIC," "3CHLOGIC," or "THEATER").

Each time you press the button, the surround/DAP/3D-PHONIC modes change as follows:

Ex. $\text{PROLOGIC} \rightarrow \text{THEATER} \rightarrow \text{3CHLOGIC} \rightarrow \text{3DACTION}^* \rightarrow \text{PAVILION}^*$

* As for the 3D-PHONIC modes (see page 27) and the DAP modes (see page 29), one of the previously selected mode appears on the display.

3. Select and play a sound source which was processed with Dolby Surround and is labeled with mark.

To cancel surround mode

Select "OFF" in step 2 above.

From the remote control:

1. Press **SOUND CONTROL** so that 10 keys work for adjusting the sound.

2. Press **SURROUND** until the mode you want appears on the display.

The previous mode is recalled at first (with its previous settings) and is shown on the display.

The indicator for that mode also lights up on the display. Each time you press the button, the surround modes change as follows:

$\text{THEATER} \rightarrow \text{3CHLOGIC} \rightarrow \text{PROLOGIC} \rightarrow \text{OFF}$

3. Select and play a sound source which was processed with Dolby Surround and is labeled with mark.

To cancel surround mode

Select "OFF" in step 2 above.

Note:
When one of the surround mode is selected, the corresponding indicator lights up on the display.

35

36

COMPU LINK Remote Control System

The COMPU LINK remote control system allows you to operate JVC audio components through the remote sensor on the receiver.

To use this remote control system, you need to connect JVC audio components through the COMPU LINK-3 (SYNCHRO) jacks with the cable (monaural mini-plug supplied with those components):

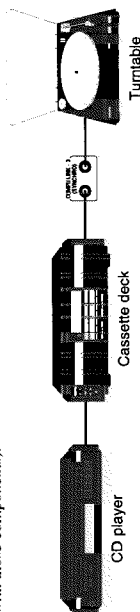

This remote control system allows you to use the four functions listed below.

Remote Control through the Remote Sensor on the Receiver

You can control JVC audio components through the remote sensor on the receiver using this remote control. Aim the remote control directly at the remote sensor on the receiver. For details, see page 38.

Automatic Source Selection

When you press the play (▶) button on a connected component or on its own remote control, the receiver automatically turns on and changes the source to the component. On the other hand, if you select a new source on the receiver or the remote control, the selected component begins playing immediately. In both cases, the previously selected source continues playing without sound for a few seconds.

Automatic Power On/Off (Standby) (only possible with the COMPU LINK-3 connection)

Both the CD player and cassette deck turn on and off (into standby mode) with the receiver.

When you turn on the receiver, the CD player or cassette deck will turn on automatically, depending on which component has been previously selected. When you turn off (into standby mode) the receiver, both the CD player and cassette deck will turn off (into standby mode).

Synchronized Recording

Synchronized recording means the cassette deck starts recording as soon as a CD (or a record) begins playing.

To use synchronized recording, follow these steps:

- 1 Put a tape in the cassette deck, and a disc in the CD player (or a record on the turntable).
- 2 Press the record (●) button and the pause (II) button on the cassette deck at the same time. This puts the cassette deck into recording pause. If you do not press the record (●) button and pause (II) button at the same time, the synchronized recording will not start.
- 3 Press the play (▶) button on the CD player (or on the turntable). The source changes on the receiver, and as soon as play starts, the cassette deck starts recording. When the play ends, the cassette deck enters recording pause, and stops about 4 seconds later.

Notes:

- Without connecting the audio components with RCA pin-plugs as described on page 8, the COMPU LINK remote control system cannot operate the components.
- Refer also to the manuals supplied with your audio components.

Notes:

- During synchronized recording, the selected source cannot be changed.
- If your CD player is playing in program mode, a 4-second blank is recorded between tracks so that the music scan feature of your cassette deck can be used on the recorded tape.
- If the power of any component is shut off during synchronized recording, the COMPU LINK remote control system may not operate properly. In this case, you must start again from the beginning.

Operating Other Components

You can operate JVC audio and video components with this receiver's remote control. To operate these components with the remote control, first select a source with the source buttons on the remote control. Then, operate that source using the remote control.

IMPORTANT:

To operate JVC audio components using this remote control:

- You need to connect JVC audio components through the COMPU LINK-3 (SYNCHRO) jacks (see page 37) in addition to the connections using cables with RCA pin plugs (see page 7).
- Aim the remote control directly at the remote sensor on the receiver.

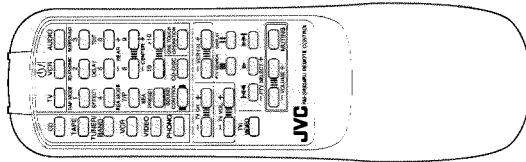

After pressing TUNER/BAND, you can perform the following operations:

- TUNER/BAND** Alternates between FM and AM (MW/LW).
 1 - 10, +10
 Selects a preset channel number directly.
 For channel number 5, press 5.
 For channel number 15, press +10, then 5.
 For channel number 20, press +10, then 10.
 For channel number 30, press +10, +10 then 10.

RDS operating buttons

- PTY SEARCH** Starts and ends searching a broadcast using the RDS.
PTY SELECT +/- Selects a program type.
DISPLAY Changes the RDS display mode.

After pressing CD, you can perform the following operations on the CD player:

- ▶ Starts playing.
 ◀ Returns to the beginning of the current (or previous) track.
 ▶▶ Skips to the beginning of the next track.
 ◀◀ Stops playing.
 || Pauses. To resume playing, press ▶.
 Selects a track number directly.
 1 - 10, +10
 For track number 5, press 5.
 For track number 15, press +10, then 5. For track number 20, press +10, then 10.
 For track number 30, press +10, +10, then 10.

After pressing CD-DISC, you can perform the following operations on the CD changer:

- 1 - 6, 7/P
 Select the number of a disc installed in a CD changer. Then continue to operate the CD player as described above.
 For example: To find a track number 11 of disc 4
 1. Press CD DISC.
 2. Press 4.
 3. Press CD.
 4. Press +10, then 1.

After pressing TAPE, you can perform the following operations on the cassette deck:

- ▶ Starts playback.
 ▶▶ Fast winds a tape from right to left.
 ◀◀ Fast winds a tape from left to right.
 || Stops operation.
 Pauses. To resume playing, press ▶.

Note:

If you choose a source on the front panel, the remote control will not operate that source.

Note:

If you press SOUND CONTROL, you cannot operate the cassette deck with this remote control. If this happens, press TAPE again, so operating buttons for audio components will work for the cassette deck.

Operating Other Components

IMPORTANT:

To operate JVC video components using this remote control:

- Aim the remote control directly at the remote sensor on the VCR or TV, not on the receiver.

After pressing VCR, you can perform the following operations on the VCR:

- ▶ Starts playback.
- ◀◀ Rewinds a video tape.
- ▶▶ Fast winds a video tape.
- Stops operation.
- Pauses. To resume playing, press ▶.

You can always do the following on the VCR:

- Change the channels on the VCR using the VCR CH +/- button.
- Turn on and off the VCR by pressing VCR in the \odot/ON (Standby/On) section.

You can always perform the following operations on the TV:

- Change the TV's input mode to either "TV" or "VIDEO" using the TV/VIDEO button.
- Change the TV volume using the TV VOL. +/- button.
- Change the channels on the TV using the TV CH +/- button.
- Turn on and off the TV by pressing TV in the \odot/ON (Standby/On) section.

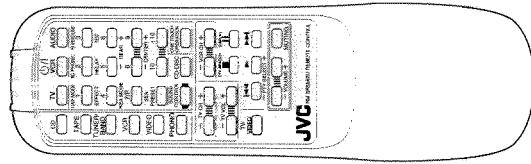

Notes:

If you choose a source on the front panel, the remote control will not operate that source.

- If you press SOUND CONTROL, you cannot operate the VCR with this remote control. If this happens, press VCR again, so operating buttons for video components will work for the VCR.
- If you press the VCR (the one for the source selection) on the remote control aiming at a JVC TV, the TV's input mode will change to the video input.

Troubleshooting

Use this chart to help you solve daily operational problems. If there is any problem you cannot solve, contact your JVC service center.

PROBLEM	POSSIBLE CAUSE	SOLUTION
The display does not light up.	The power cord is not plugged in or the \odot POWER switch is press to set in the \blacksquare OFF position.	Plug the power cord into an AC outlet and/or press \odot POWER to set it in the \blacksquare ON position.
No sound from speakers.	Speaker signal cables are not connected.	Check speaker wiring and reconnect if necessary.
	The SPEAKERS 1 and 2 buttons is not set correctly.	Press SPEAKERS 1 and 2 to set it in the \blacksquare ON position.
	An incorrect source is selected.	Select the correct source.
"OVERLOAD" starts flashing on the display.	Speakers are over-loaded because of high volume.	Rotate the MASTER VOLUME control counterclockwise three or four times then press STANDBY/ON \odot/ON on the front panel. If "OVERLOAD" does not disappear, unplug the AC power cord, then plug it back again. Do not use the remote control when "OVERLOAD" is shown on the display.
	Speakers are over-loaded because of short circuit of speaker terminals.	Press STANDBY/ON \odot/ON on the front panel then check the speaker wiring. If "OVERLOAD" does not disappear, unplug the AC power cord, then plug it back again. Do not use the remote control when "OVERLOAD" is shown on the display. If speaker wiring is not short circuited, contact your dealer.
Sound from one speaker only.	Speaker signal cables are not connected properly.	Check speaker wiring and reconnect if necessary.
	The balance is set to one extreme.	Adjust the balance properly (see page 12).
Continuous hiss or buzzing during FM reception.	Incoming signal is too weak.	Connect an outside FM antenna or contact your dealer.
	The station is too far away.	Select a new station.
	An incorrect antenna is used.	Check with your dealer to be sure you have the correct antenna.
	Antennas are not connected properly.	Check connections.
Occasional cracking noise during FM reception.	Ignition noise from automobiles.	Move the antenna farther from automobile traffic.
Howling during record playing.	Your turntable is too close to speakers.	Move speakers away from the turntable.
Remote control does not work.	There is an obstruction in front of the remote sensor on the receiver.	Remove the obstruction.
	Batteries are weak.	Replace batteries.

Amplifier

Output Power	At Stereo operation Front channels	55 watts per channel, min. RMS, driven into 4 ohms at 1 kHz, with no more than 0.9 % total harmonic distortion. (IEC268-3/DIN)
	At Stereo operation Rear channels	30 watts per channel, min. RMS, driven into 8 ohms at 1 kHz, with no more than 0.9 % total harmonic distortion. (IEC268-3/DIN)
	At Surround operation Front channels	30 watts per channel, min. RMS, driven into 8 ohms, 40 Hz to 20 kHz, with no more than 0.8 % total harmonic distortion.
	At Surround operation Rear channels	50 watts per channel, min. RMS, driven into 8 ohms at 1 kHz, with no more than 0.8 % total harmonic distortion.
	Center channel	50 watts, min. RMS, driven into 8 ohms at 1 kHz, with no more than 0.8 % total harmonic distortion.
	Rear channel	50 watts, min. RMS, driven into 8 ohms at 1 kHz, with no more than 0.8 % total harmonic distortion.
Total Harmonic Distortion (8 ohms, 1 kHz)		0.8 %* at 30 watts output (* Measured by JVC Audio Analysis System)
Frequency Response (8 ohms)	PHONO (MM) CD, TAPE, VIDEO, VCR	20 Hz to 20 kHz (±1 dB) 20 Hz to 20 kHz (±1 dB)
Audio Input Sensitivity/Impedance (1 kHz)	PHONO CD, TAPE, VIDEO, VCR	1.8 mV/47 k ohms 160 mV/47 k ohms
Audio Output Level	TAPE, VCR	160 mV
Signal-to-Noise Ratio (66 IHP/DIN)	PHONO CD, TAPE, VIDEO, VCR	70 dB/66 dB 87 dB/67 dB
RIAA Phono Equalization		±0.5 dB (20 Hz to 20 kHz)
Loudness control (Volume Control at -60 dB)		±5 ±2 dB at 100 Hz

FM tuner (IHF)

Tuning Range	87.5 MHz to 108.0 MHz
Usable Sensitivity	12.7 dBf (1.2 µV/75 ohms)
50 dB Quieting Sensitivity	Monaural Stereo
Signal-to-Noise Ratio (IHF-A weighted)	Monaural Stereo
Total Harmonic Distortion	Monaural Stereo
Stereo Separation at REC OUT	40 dB at 1 kHz
Capture Ratio	1.5 dB (10 mV)
Alternate Channel Selectivity	60 dB: (±400 kHz)
Frequency Response	30 Hz to 15 kHz: (+0.5 dB, -3 dB)

AM (MW/LW) tuner

Tuning Range	522 kHz to 1,629 kHz (MW) 144 kHz to 288 kHz (LW)
Usable Sensitivity	Loop antenna 300 µV/m (MW) 600 µV/m (LW)
Signal-to-Noise Ratio	50 dB (100 mV/m)

General

Power Requirements	AC 230 V _~ , 50 Hz
Power Consumption	240 watts 5 watts (in standby mode)
Dimensions (W x H x D)	435 x 146 x 403 mm (17 1/8 x 5 7/8 x 15 7/8 inches)
Mass	8.5 kg (18.8 lbs)

Design & specifications are subject to change without notice.

RX554RBK

- MEMO -

Description of major ICs

■ MN173222JABN1(IC401):System Control Micon

1. Terminal Layout

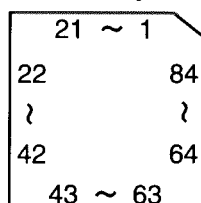

2. Key Matrix

	KEY IN 0	KEY IN 1	KEY IN 2	KEY IN 3
KEY OUT 0	POWER S401	—	—	—
KEY OUT 1	SURROUND S402	PRESET SEA S403	TUNER/BAND S404	SETTING S405
KEY OUT 2	SOURCE S406	ADJUST S407	ONE TOUCH OPERATION S408	MEMORY S409
KEY OUT 3	◁S410	▷S411	△S412	▽S413
KEY OUT 5	E ON S417	TA/NEWS/INFO S418	PTY SELECT S419	DISPLAY MODE S420

3. Pin Function

Pin No.	Synbol	I/O	Function	Pin No.	Synbol	I/O	Function
1	IN1	I	JOG VOLUME control	52	CE	O	Chip enable to IC121
2	IN2	I	JOG VOLUME control	53	CK	O	Clock signal to IC121
3	VIDEO1	O	Video select signal	54	DI	I	Data signal from IC121
4	VIDEO2	O	Video select signal	55	DO	O	Data signal to IC121
5	PROTECT	I	Protector signal input	56	DCSI	I	COMPULINK signal input
6	POWER	O	Power ON/OFF control	57	DCSO	O	COMPULINK signal output
7	KI0	I	Key matrix input	58	DSP ERR	I	Error flag input
8	KI1	I	Key matrix input	59	DSP IFOK	I	Oration flag input
9	KI2	I	Key matrix input	60	DSP ACK	I	Acknowledge signal input
10	KI3	I	Key matrix input	61	DSP CS	O	Chip serect signal output
11	VCR S/C	I	VCR S/C serect signal input	62	T.MUTE	O	Tuner mute signal output
12	G11	O	Grid control signal output	63	S.MUTE	O	Source muting control
13	G10	O	Grid control signal output	64	TV CONT	-	Pull down
14	G9	O	Grid control signal output	65	TV OUT	-	Pull down
15	G8	O	Grid control & Key matrix output	66	VCR OUT	-	Pull down
16	G7	O	Grid control & Key matrix output	67	VCR IN	-	Pull down
17	G6	O	Grid control & Key matrix output	68	RESET IN	I	Reset signal input
18	G5	O	Grid control & Key matrix output	69	X1	-	Connect to GND
19	G4	O	Grid control signal output	70	X2	-	Non connect
20	G3	O	Grid control & Key matrix output	71	Vss	-	Connect to GND
21	G2	O	Grid control & Key matrix output	72	OSC2	-	Oscillation terminal
22	G1/KO7	O	Grid control & Key matrix output	73	OSC1	-	Oscillation terminal
23	Vpp	-	Power supply for FL display	74	VDD	-	Power supply
24~39	S1~S16	O	Segment control signal output	75	SET.I	O	SETTING indication control
40	DVD S/C	I	DVD S/C select signal input	76	ADJ.I	O	ADJUST indication control
41	CLK.D	O	Clock signal to IC601	77	SURR.I	O	SURROUND indication control
42	DATA OUT	O	Data signal to IC601	78	SOURCE.I	O	SOURCE indication control
43	DATA IN	I	Data signal from IC601	79	SEA.I	O	S.E.A. indication control
44	INH	I	Inhibit signal input	80	BAND.I	O	TUNER/BAND indication contorl
45	RDS CLK	O	Clock signal output	81	STB	O	Strobe signal to IC341~343.252.321.322
46	RDS DATA	I	Data signal input	82	DATA	O	Data signal to IC341~343.252.321.322.404
47	RDSRESET	O	Reset signal output				
48	RM	I	Remocon signal from IC402	83	CLK	O	Clock signal to IC341~343.252.321.322.404
49	D-START	I	Data start signal input				
50	STEREO	I	Stereo signal input				
51	TUNED	I	Tuning signal input	84	STB(EX)	O	Strobe signal to IC404

■ TC9471F(IC601):Dolby Prologic

1. Block Diagram

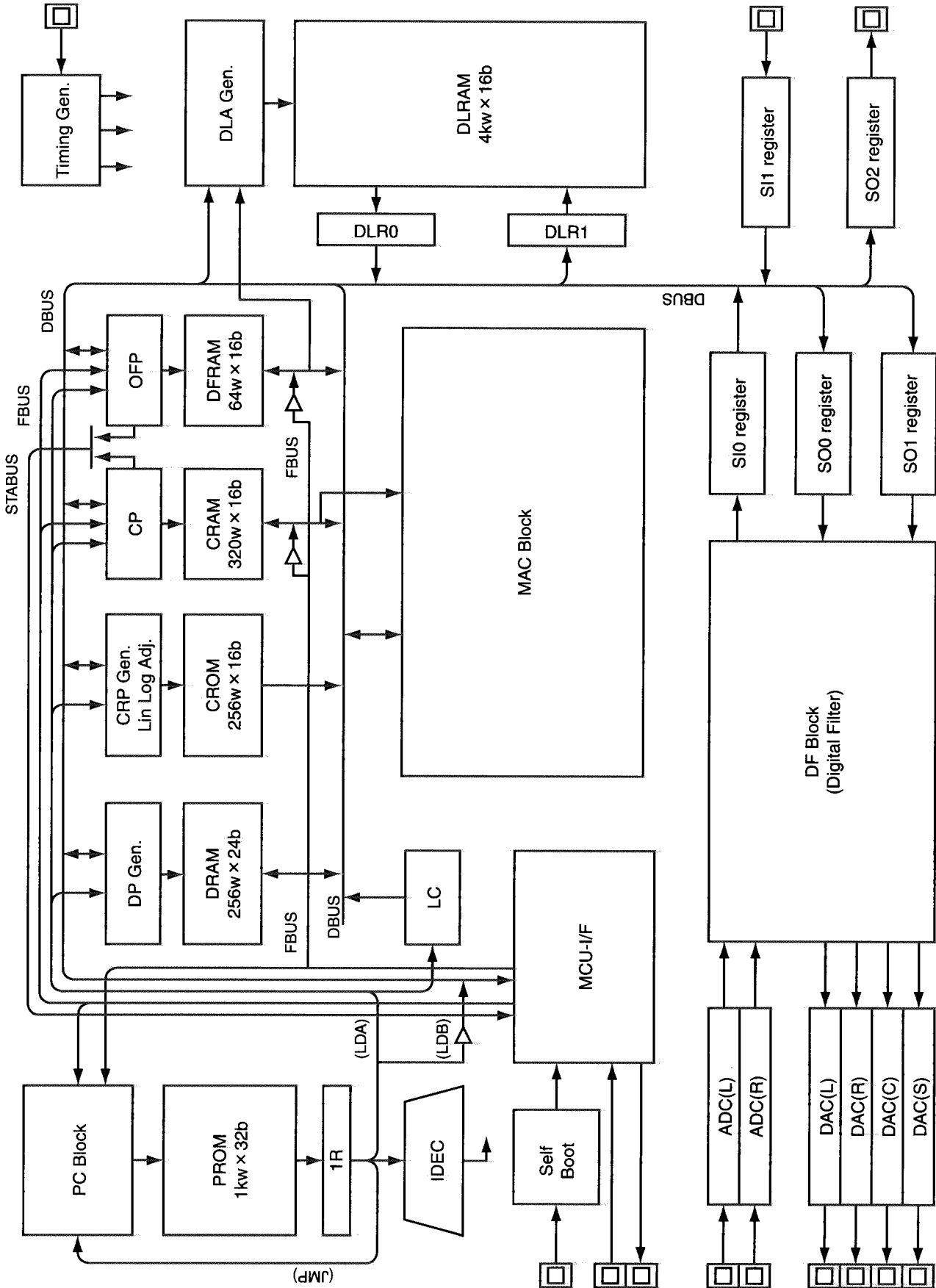

2-a.Pin Function

Pin No.	Symbol	I/O	Function
1	ECKO	O	Amplifier output terminal for external clock input.
2	ECKI	I	Amplifier input terminal for external clock input.
3	GNDX	-	Ground terminal.(For crystal oscillator circuit)
4	GNDAL	-	Ground terminal.(For DAC L channel)
5	AOL	O	DAC analog signal output terminal.(L channel)
6	VRL	-	Reference voltage terminal.(For DAC L channel)
7	VDAL	-	Power supply terminal.(For DAC L channel)
8	VDAR	-	Power supply terminal.(For DAC R channel)
9	VRR	-	Reference voltage terminal.(For DAC R channel)
10	AOR	O	DAC analog signal output terminal.(R channel)
11	GNDAR	-	Ground terminal.(For DAC R channel)
12	GNDAC	-	Ground terminal.(For DAC C channel)
13	AOC	O	DAC analog signal output terminal.(C channel)
14	AOCT	O	DAC analog signal output terminal with attenuator.(For C channel)
15	VRC	-	Reference voltage terminal.(For DAC C channel)
16	VDAC	-	Power supply terminal.(For DAC C channel)
17	VRO	O	Reference voltage terminal for attenuator.(Output buffer)
18	VRI	I	Reference voltage terminal for attenuator.(Input buffer)
19	VDAS	-	Power supply terminal.(For DAC S channel)
20	VRS	-	Reference voltage terminal.(For DAC S channel)
21	AOST	O	DAC analog signal output terminal with attenuator.(For S channel)
22	AOS	O	DAC analog signal output terminal.(S channel)
23	GNDAS	-	Ground terminal.(For DAC S channel)
24	GND	-	Ground terminal.
25~29	TP0~4	O	Test data output terminal, normally open.
30	VDD	-	Power supply terminal.
31	VDDR	-	Power supply terminal.(For DLRAM)
32	GNDR	-	Ground terminal.(For DLRAM)
33~40	TP5~12	O	Test data output terminal, normally open.
41	FS	O	Clock output terminal.(1fs)
42	CKO0	O	Clock output terminal 0.
43	CKO1	O	Clock output terminal 1.
44	GND	-	Ground terminal.
45	TP13	O	Test data output terminal, normally open.
46	MCK	O	Master clock output terminal.(256fs/512fs/(384/768fs))
47	VDD	-	Power supply terminal.
48~53	TP14~19	O	Test data output terminal, normally open.
54	CKS	I	Master clock select terminal.
55	STEP0	I	Operation step select terminal 0.
56	STEP1	I	Operation step select terminal 1.
57	RST	I	Reset signal input terminal.

2-b.Pin Function

Pin No.	Symbol	I/O	Function
58	VDD	-	Power supply terminal
59	SYNC	I	Synchronous signal input terminal.
60	ELRO	I	LR clock input terminal for serial data output.
61	ELRI	I	LR clock input terminal for serial data input.
62	EBCO	I	Bit clock input terminal for serial data output.
63	EBCI	I	Bit clock input terminal for serial data input.
64	DIN	I	Serial data input terminal.
65	DOUT	O	Serial data output terminal.
66	EM0	I	De-emphasis select terminal 0.
67	EM1	I	De-emphasis select terminal 1.
68	IFF0	I	Interface flag terminal 0.
69	IFF1	I	Interface flag terminal 1.
70	IFF2	I	Interface flag terminal 2.
71	GND	-	Ground terminal.
72	CS	I	Chip select signal input terminal.(MCU interface)
73	IFCK	I	Data sift clock input terminal.(MCU interface)
74	IFDI	I/O	Data input terminal.(MCU interface) At the IC bus mode,data input /output terminal.
75	IFDO	O	Data output terminal.(MCU interface) At the IC bus mode,normally open.
76	IFOK	O	Operation flag output terminal.(MCU interface)
77	ACK	O	Acknowledge signal output terminal.(MCU interface)
78	ERR	O	Error flag output terminal.(MCU interface)
79	I2CS	I	IC bus mode select terminal.
80	BOOT	I	Self-boot control terminal.
81	BA0	I	Boot address select terminal 0.
82	BA1	I	Boot address select terminal 1.
83	VDD	-	Power supply terminal.
84~87	TST0~3	I	Test data input terminal,normally fixed"L"level
88	GND	-	Ground terminal.
89	VSAL	-	Analog ground terminal.(For ADC L channel)
90	LIN	I	ADC analog signal input terminal.(L channel)
91	AVRL	-	Reference voltage terminal.(For ADC L channel)
92	VDL	-	Analog power supply terminal.(For ADC L channel)
93	VDR	-	Analog power supply terminal.(For ADC R channel)
94	AVRR	-	Reference voltage terminal.(For ADC R channel)
95	RIN	I	ADC analog signal input terminal.(R channel)
96	VSAR	-	Analog ground terminal.(For ADC R channel)
97	GNDX	-	Ground terminal.(For crystal oscillator circuit)
98	XI	I	Crystal oscillator connection terminal.(input)
99	XO	O	Crystal oscillator connection terminal.(output)
100	VDX	-	Power supply terminal.(For crystal oscillator circuit)

■ BU2092(IC404):PORT EXPANDER

1.Terminal Layout

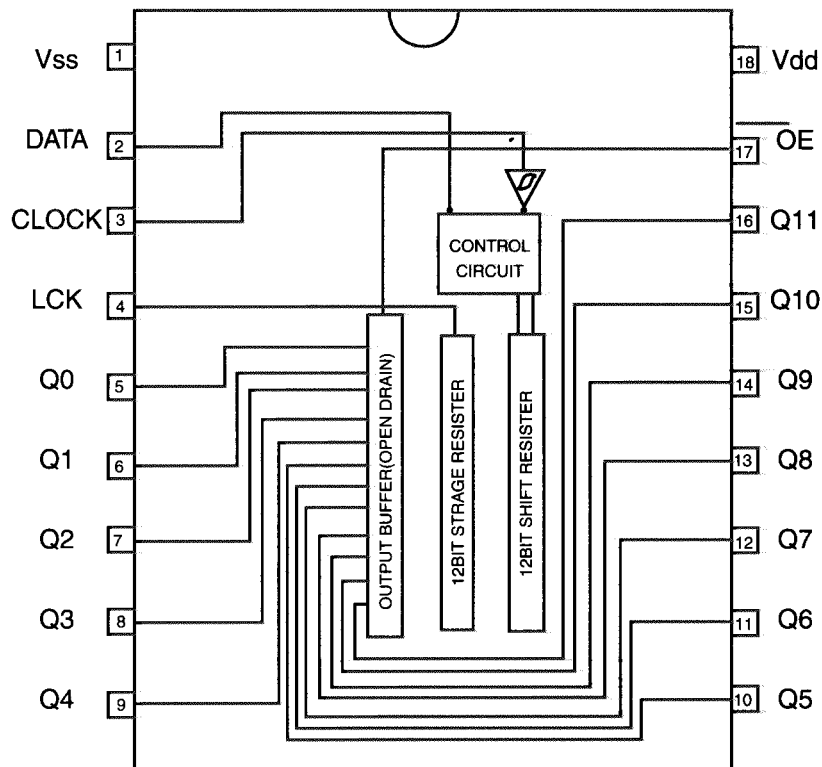

2.Pin Function

Pin No.	Symbol	I/O	Function						
1	Vss	-	Connect to GND						
2	DATA	I	Serial Data input						
3	CLOCK	I	Shift Clock of Data						
4	LCK	I	Latch Clock of Data						
5~16	Q0~Q11	O	Parallel Data Output <table border="1" style="margin-left: 20px;"> <tr> <td>Latch Data</td> <td>L</td> <td>H</td> </tr> <tr> <td>OUTPUT</td> <td>ON</td> <td>OFF</td> </tr> </table>	Latch Data	L	H	OUTPUT	ON	OFF
Latch Data	L	H							
OUTPUT	ON	OFF							
17	$\overline{\text{OE}}$	I	Output Enable						
18	Vdd	-	Power Supply						

■TC9413AP(IC343):Rear/Center/Sub.W Volume Control

1.Block Diagram

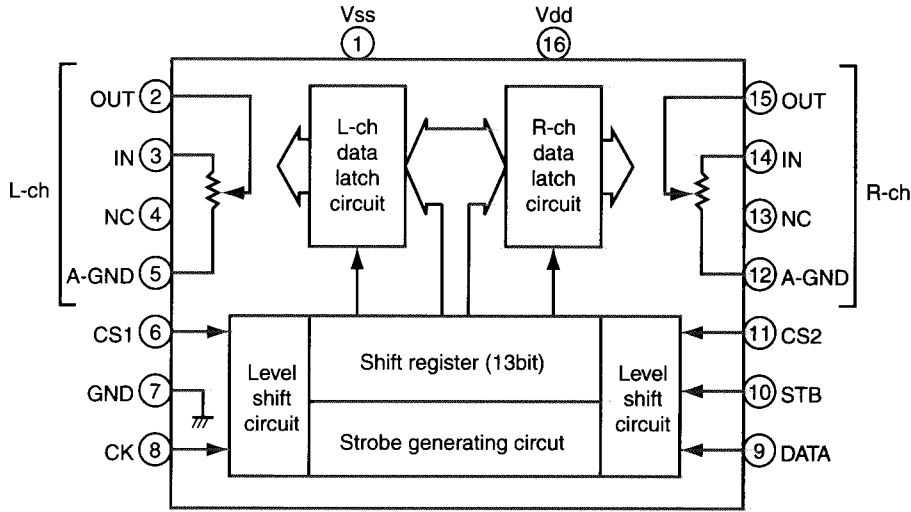

2.Description

Pin No.	Symbol	I/O	Function
1	Vss	-	Negative Power supply
2	L-OUT	O	L-ch Volume output
3	L-IN	I	L-ch Volume input
4	NC	-	Non connect
5	L-A-GND	-	Analog GND
6	CS1	I	Chip select input
7	GND	-	Digital GND
8	CK	I	Data transfer clock input
9	DATA	I	Volume setup serial data input
10	STB	I	Data write strobe input
11	CS2	I	Chip select input
12	R-A-GND	-	Analog GND
13	NC	-	Non connect
14	R-IN	I	R-ch Volume input
15	R-OUT	O	R-ch Volume output
16	Vdd	-	Positive power supply

■ TC9412AP(IC341):Main Volume Control

1. Block Diagram

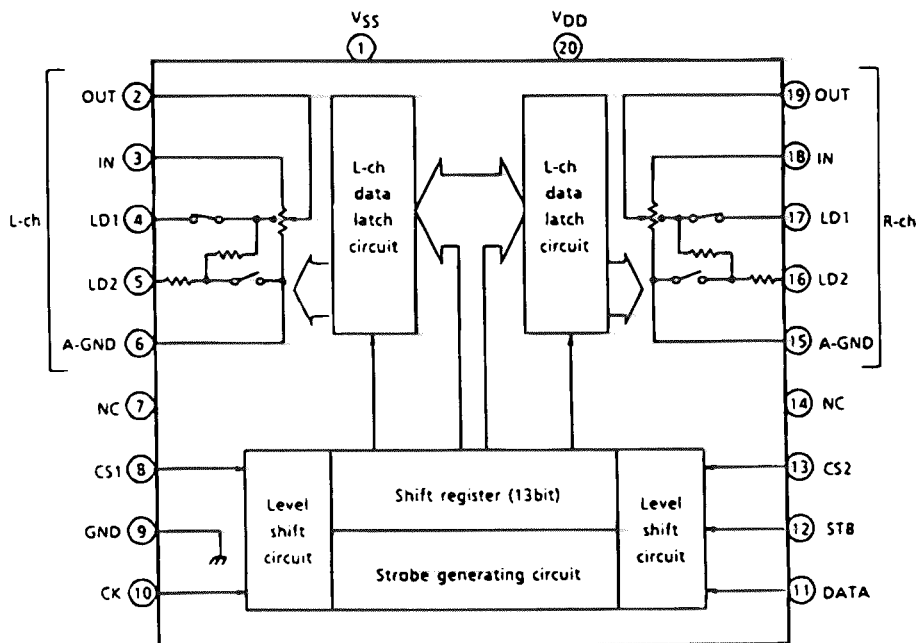

2. Description

Pin No.	Symbol	I/O	Function
1	Vss	-	Negative Power supply
2	L-OUT	O	L-ch Volume output
3	L-IN	I	L-ch Volume input
4	L-LD1	O	Loudness tap output pin
5	L-LD2	O	Loudness tap output pin
6	L-A-GND	-	Analog GND pin
7	NC	-	Non connect
8	CS1	I	Chip select input pin
9	GND	-	Digital GND pin
10	CK	I	Clock input pin
11	DATA	I	Data input pin
12	STB	I	Strobe input pin
13	CS2	I	Chip select input pin
14	NC	-	Non connect
15	R-A-GND	-	Analog GND pin
16	R-LD2	O	Loudness tap output pin
17	R-LD1	O	Loudness tap output pin
18	R-IN	I	Volume input pin
19	R-OUT	O	Volume output pin
20	VDD	-	Positive power supply pin

■ LC72131(IC121):PLL Synthesizer

1. Terminal Layout

XIN	1	22	XOUT
	2	21	VSS
PLLCE	3	20	LPF OUT
PLLDA	4	19	LPF IN
PLLCK	5	18	PD
IFDATA	6	17	VDD
FM	7	16	FM OSC
MW	8	15	AM OSC
LW	9	14	
AUTO/MONO	10	13	IF REQ
POWER	11	12	FM/AM IF

2. Block Diagram

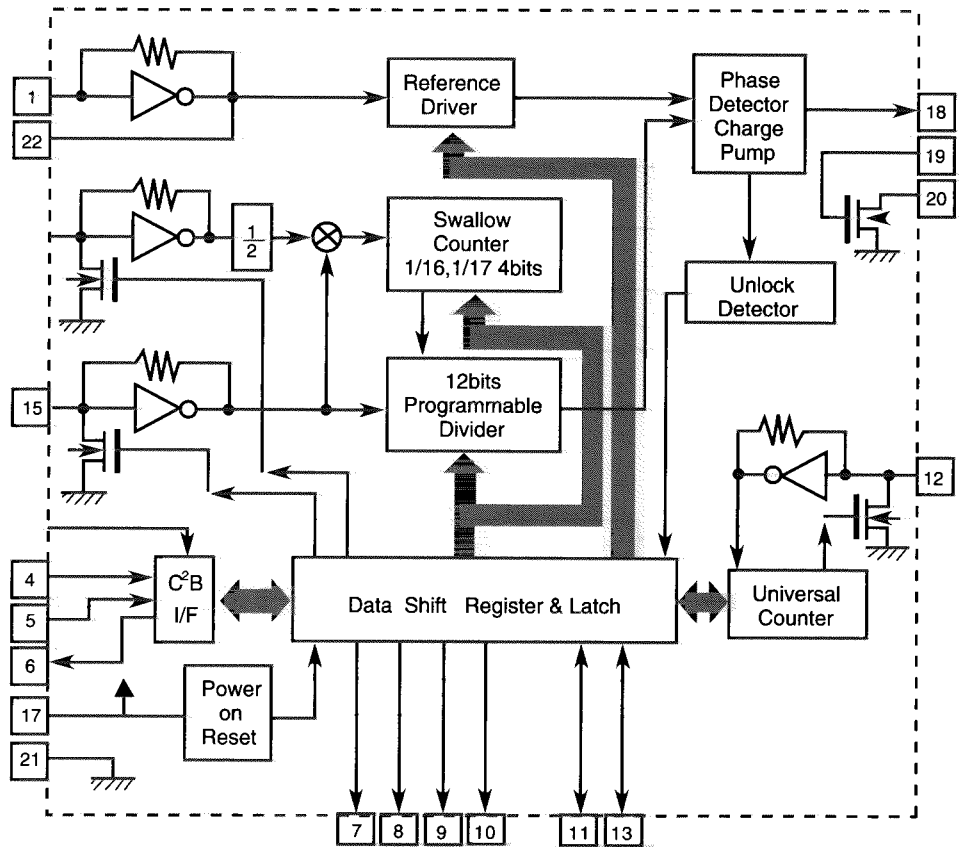

3. Pin Functions

Pin No.	Symbol	I/O	Functions	Pin No.	Symbol	I/O	Functions
1	Xin	I	Crystal oscillator (7.2MHz).	12	FM/AM IF	I	Universal counter input
2		--	Not use	13	IF REQ	O	Output the "IF-signal request" to IC102
3	PLLCE	I	Fix the chip enable to "H" when inputting (DI) and outputting (DO) the serial data	14		I	Not use
4	PLLDA	I	Receive the control data from the controller (IC801).	15	AMOSC	I	Input the local oscillator signal of AM.
5	PLLCK	I	This clock is used to synchronize data when transmitting the data of DI and DO.	16	FM OSC	I	Input the local oscillator signal of FM.
6	IFDATA	O	Transmit the data from LC72131 to the controller which is synchronized with CK.	17	VDD	O	This is a terminal of power supply.
7	FM	O	It is "L" on FM mode.	18	PD	O	PLL charge pump output : When the local oscillator signal frequency is higher than the reference frequency high level signals will output. When it is lower than the reference frequency, low level signals will output. When it is same as reference frequency signals, it will be floating.
8	MW	O	It is "L" on MW mode.	19	LPF IN	I	Transistor used for the PLL active low-pass filter
9	LW	O	It is "L" on LW mode.	20	LPF OUT	O	Transistor used for the PLL active low-pass filter
10	AUTO/MONO	O	It is "L" on monaural, "L" on auto	21	VSS	--	Connected toGND
11	POWER	O	Regulator control signal P ON "H", STANDBY "L"	22	X out	O	Crystal oscillator(7.2MHz).

■ LA1837(IC102): FM AM IF AMP&detector, FM MPX Decoder

1. Block Diagram

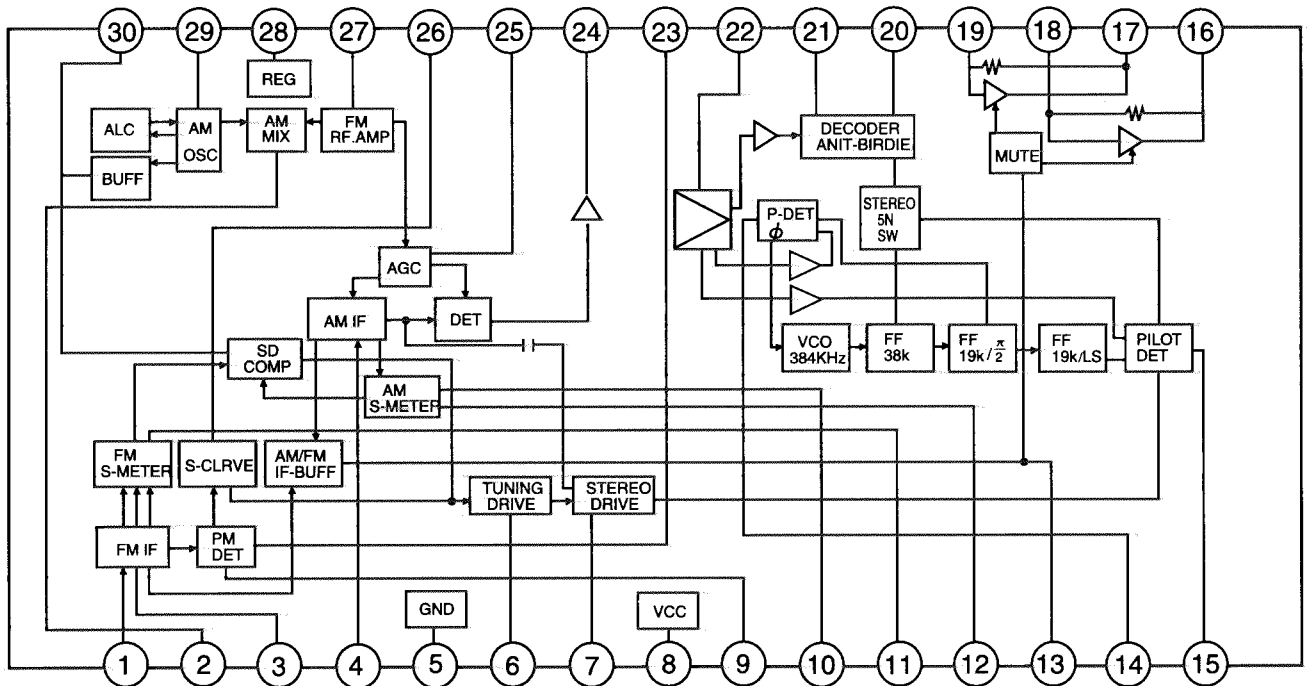

3. Pin Function

Pin No.	Symbol	I/O	Function	Pin No.	Symbol	I/O	Function
1	FM IN	I	This is an input terminal of FM IF signal.	16	L OUT	O	Left channel signal output.
2	AM MIX	O	This is an out put terminal for AM mixer.	17	R OUT	O	Right channel signal output.
3	FM IF	I	Bypass of FM IF	18	L IN	I	Input terminal of the Left channel post AMP.
4	AM IF	I	Input of AM IF Signal.	19	R IN	I	Input terminal of the Right channel post AMP.
5	GND	-	This is the device ground terminal.	20	RO	O	Mpx Right channel signal output.
6	TUNED	O	When the set is tuning,this terminal becomes "L".	21	LO	O	Mpx Left channel signal output.
7	STEREO	O	Stereo indicator output. Stereo "L", Mono: "H"	22	IF IN	I	Mpx input terminal
8	VCC	-	This is the power supply terminal.	23	FM OUT	O	FM detection output.
9	FM DET	-	FM detect transformer.	24	AM DET	O	AM detection output.
10	AM SD	-	This is a terminal of AM ceramic filter.	25	AM AGC	I	This is an AGC voltage input terminal for AM
11	FM VSM	O	Adjust FM SD sensitivity.	26	AFC	-	This is an output terminal of voltage for FM-AFC.
12	AM VSM	O	Adjust AM SD sensitivity.	27	AM RF	I	AM RF signal input.
13	MUTE	I/O	When the signal of IF REQ of IC121(LC72131) appear, the signal of FM/AM IF output. //Muting control input.	28	REG	O	Register value between pin 26 and pin28 desides the frequency width of the input signal.
14	FM/AM	I	Change over the FM/AM input. "H" :FM, "L" : AM	29	AM OSC	-	This is a terminal of AM Local oscillation circuit.
15	MONO/ST	O	Stereo : "H", Mono: "L"	30	OSC BUFFER	O	AM Local oscillation Signal output.

RX554RBK

■ SAA6579T(IC192):RDS Detector

1. Terminal Layout

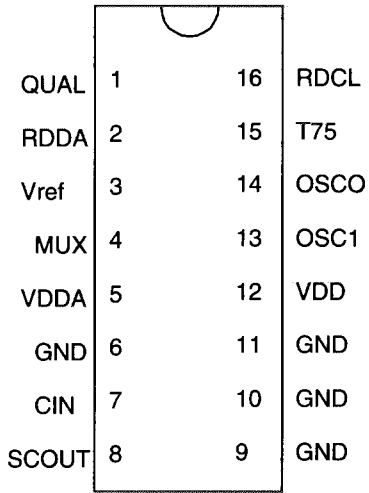

2. Pin Function

Pin No	Symbol	I/O	Function
1	QUAL	--	Non connection
2	RDDA	O	RDS data output
3	Vref	O	Reference voltage output
4	MUX	I	Multiplex signal input
5	VDDA	--	+5Vsupply voltage for analog
6	GND	--	Ground for analog part(0V)
7	CIN	I	Subcarrier outputof reconstruction filter
8	SCOUT	O	Ground for digital part(0V)
9	GND	--	Ground for digital part(0V)
10	GND	--	Ground for digital part(0V)
11	GND	--	Ground for digital part(0V)
12	VDD	--	+5Vsupply voltage fordigital part
13	OSC1	I	Oscilator input
14	OSCO	O	Oscilator OUTput
15	T75	--	Non connection
16	RDCL	O	RDS clock output

3. Block Diagram

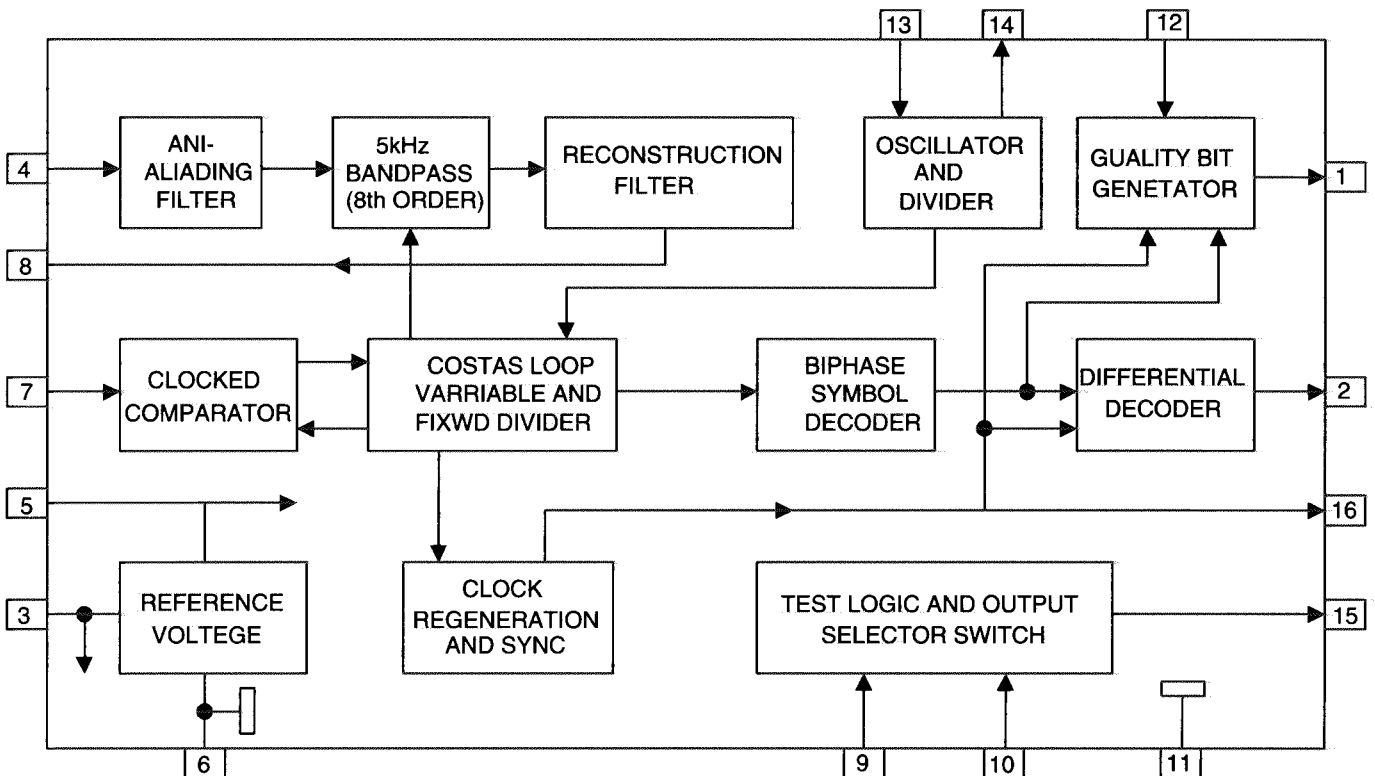

■ M5243P12(IC251):S.E.A. Graphic Equalizer

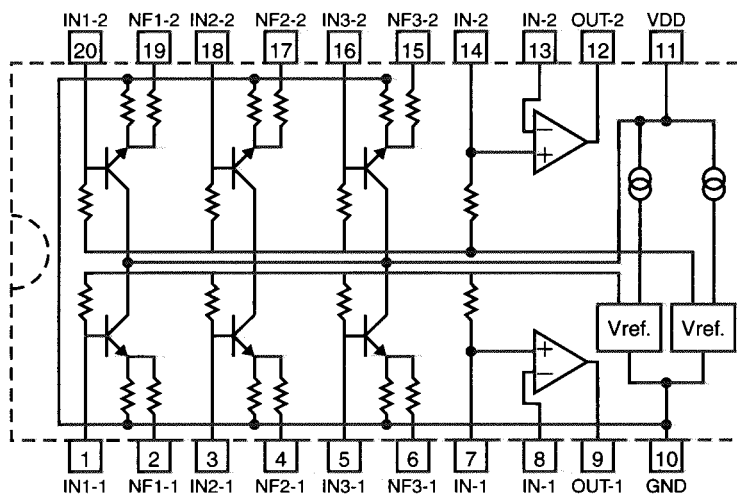

■ LC7073(IC191):Radio Data System

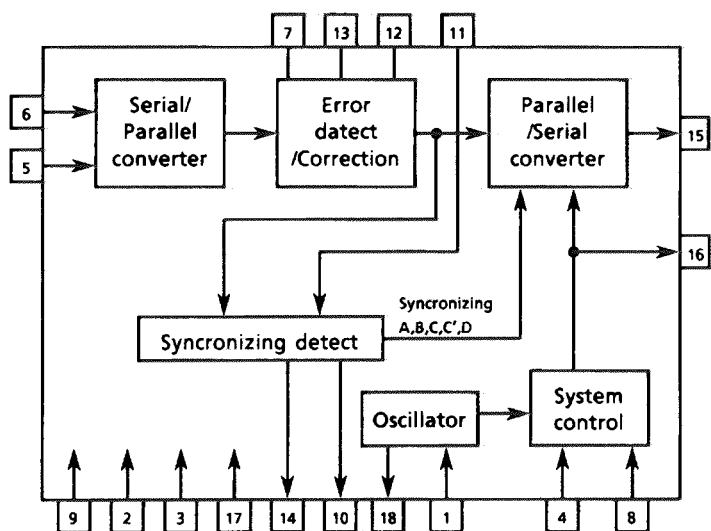

RX554RBK

■ NJM2246D(IC201):Video Switch

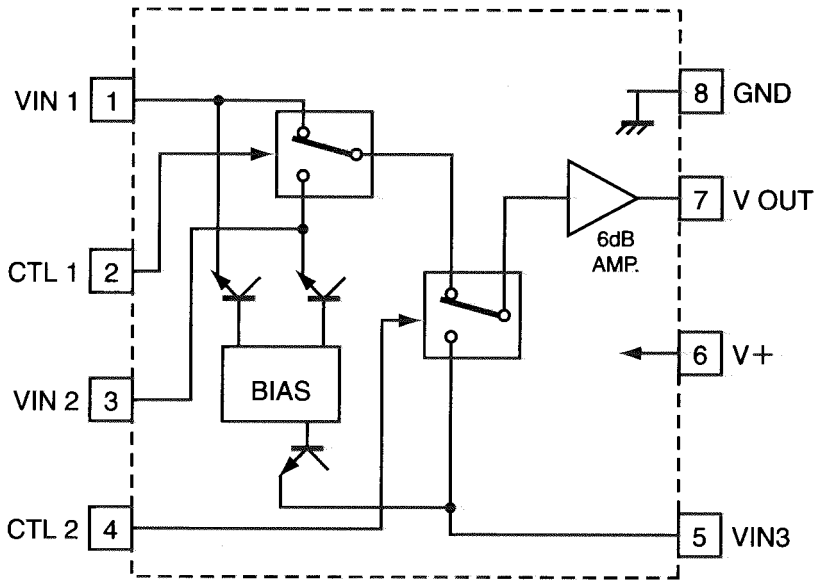

Control Signal - Output Signal

CTL 1	CTL 2	Output
L	L	VIN 1
H	L	VIN 2
L/H	H	VIN 3

Disassembly Procedures

(1) Top cover removal (See Fig.1)

1. Remove 4 screws A on both sides of the top cover and 3 screws B on the rear side.
2. Lift the back of the top cover spreading both sides to remove.

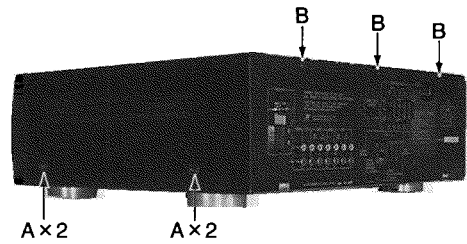

Fig.1

(2) Front panel assembly removal (See Fig.2,3)

1. Remove the top cover.
2. Remove 3 screws C on the bottom side and 3 screws D on the top side.
3. Disconnect the wire CN811 on the MAIN P.C.Board.
4. Disconnect the wire CN304 on the INPUT P.C.Board.
5. Disconnect the connector CN112 on the TUNER P.C.Board.
6. Remove the front panel assembly.

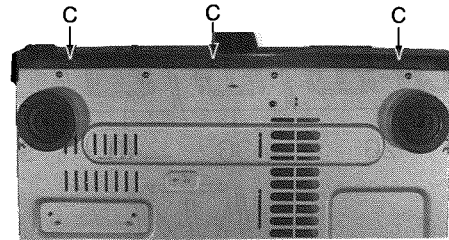

Fig.2

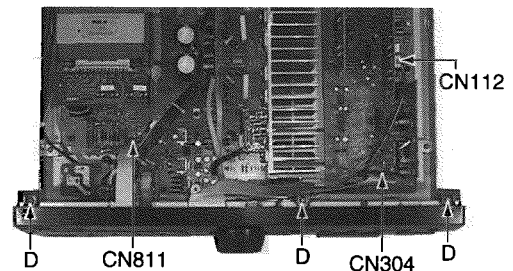

Fig.3

(3) Rear panel remove (See Fig.4)

1. Remove the top cover.
2. Remove 13 screws E and 2 screws F on the rear panel.
3. Remove the power cord stopper up side.
4. Remove the rear panel.

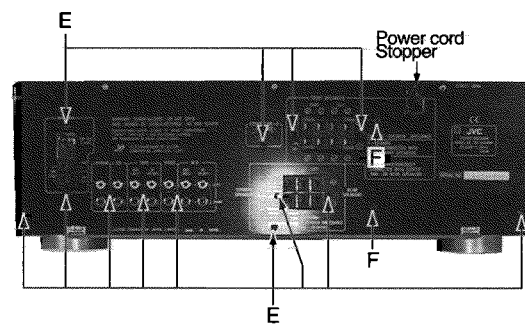

Fig.4

(4) Remove TUNER P.C.Board (See Fig.5)

1. Disconnect the connector CN111 on the INPUT P.C.Board.

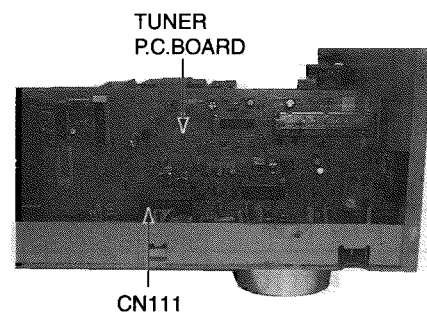

Fig.5

(5) INPUT P.C.BOARD Removal (Fig.6)

1. Disconnect the connector CN712 on the AMP P.C.Board.
2. Pullout the connected P.C.Board.
3. Remove 4 screws H on the INPUT P.C.Board.
4. Remove the INPUT P.C.Board.

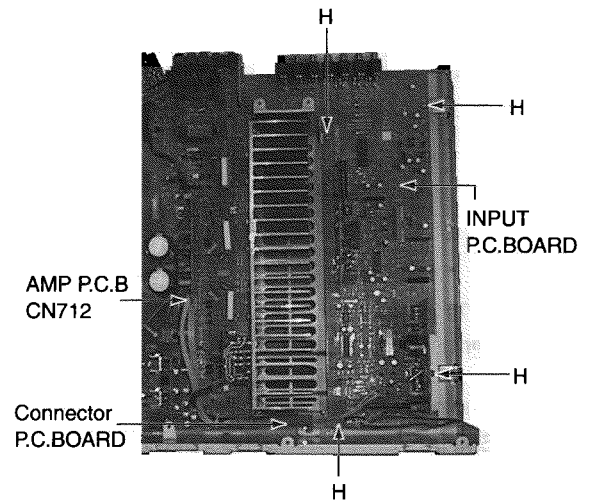

Fig.6

(6) MAIN P.C.BOARD Removal (Fig.7,8)

1. Remove 7 screws I on the MAIN P.C.Board.
2. Remove 8 screws J on the Power transistor.
3. Each tyi band is cut out.
4. Disconnect the wire CN831 on the MAIN P.C.Board.
5. Pull out the AMP P.C.Board.
6. Remove 4 screws N on Power Transformer.
7. Remove 4 screws K on push switch of the front side.
8. Remove nut on terminal of the headphone.
9. Remove the MAIN P.C.Board.

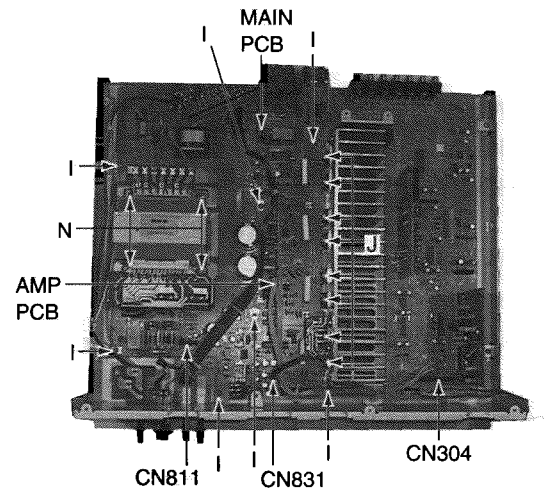

Fig.7

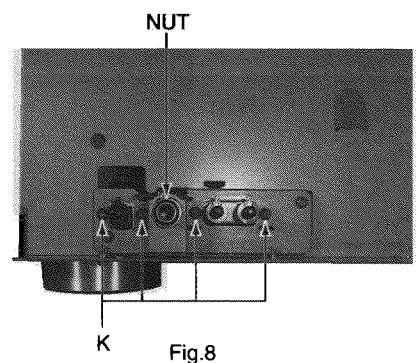

Fig.8

(7) Front P.C.BOARD Removal (Fig.9)

1. Remove the top cover.
2. Remove the Front panel assembly.
3. Remove the master volume knob and nut.
4. Remove the 13 screws L on the Front P.C.Board.

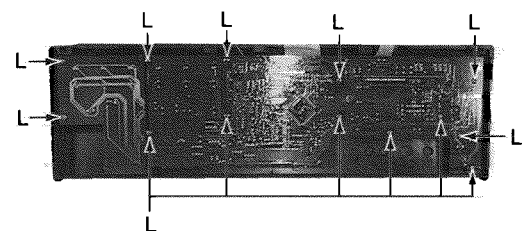

Fig.9

ADJUSTMENT PROCEDURES

■ TUNER SECTION

1. Tuner range

FM	87.5MHz~108.0MHz
MW	522kHz~1629kHz
LW	144kHz~288kHz

2. Tuning voltage

Confirm the voltages in the table at TP101

FM tuning voltage (Unit V)

87.5MHz	> 1.3 (Standard 1.6)
108.0MHz	< 9.0 (Standard 8.0)

MW tuning voltage (Unit V)

522kHz	> 0.7 (Standard 0.9)
1629kHz	< 8.3 (Standard 7.5)

LW tuning voltage (Unit V)

144kHz	>0.7 (Standard 1.0)
288kHz	<7.5 (Standard 5.0)

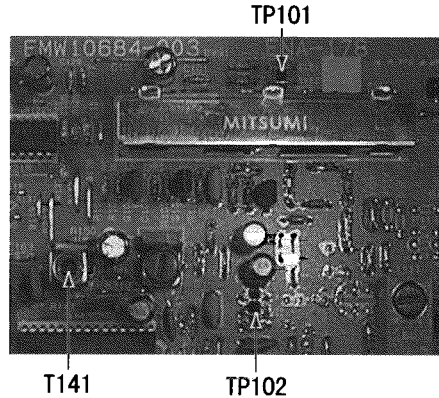

3. FM center meter

Receive a broadcast by using the function of 'AUTO STOP'

Adjust T141 (Detector coil) so that the voltage at TP102 becomes $0 \pm 1.5\text{mV}$

■ POWER AMPLIFIER SECTION

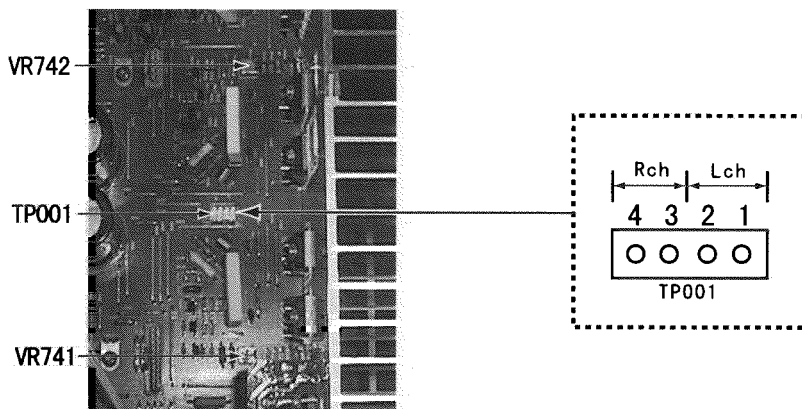

IDLING CURRENT

1. Set the volume control to minimum during this adjustment. set the surround mode "OFF"
2. Turn VR741 and VR742 fully counterclockwise to warm up before adjustment.
If the heat sink is already warm from previous use the correct adjustment can not be made.
3. For L-ch, connect a DC voltmeter between TP001's pin1 and pin2 (Lch)
And, connect it between pin3 and pin4 (Rch).
4. 30 minutes later after power on, adjust VR741 for L-ch, or VR742 for R-ch so that the DC voltmeter value has 1mV~10mV.

■ Amplifier/Control section

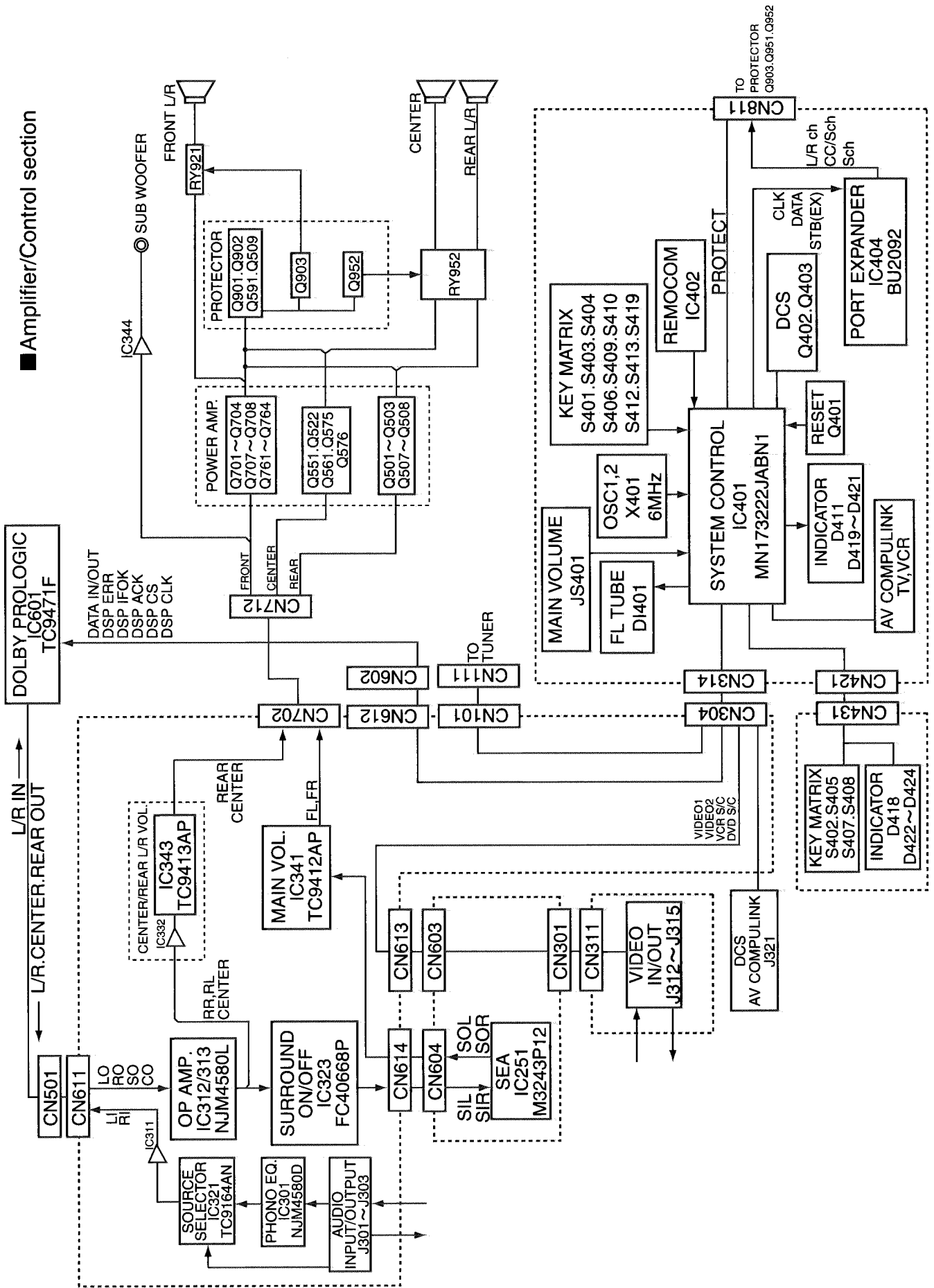

RX554RBK

■ Tuner Section

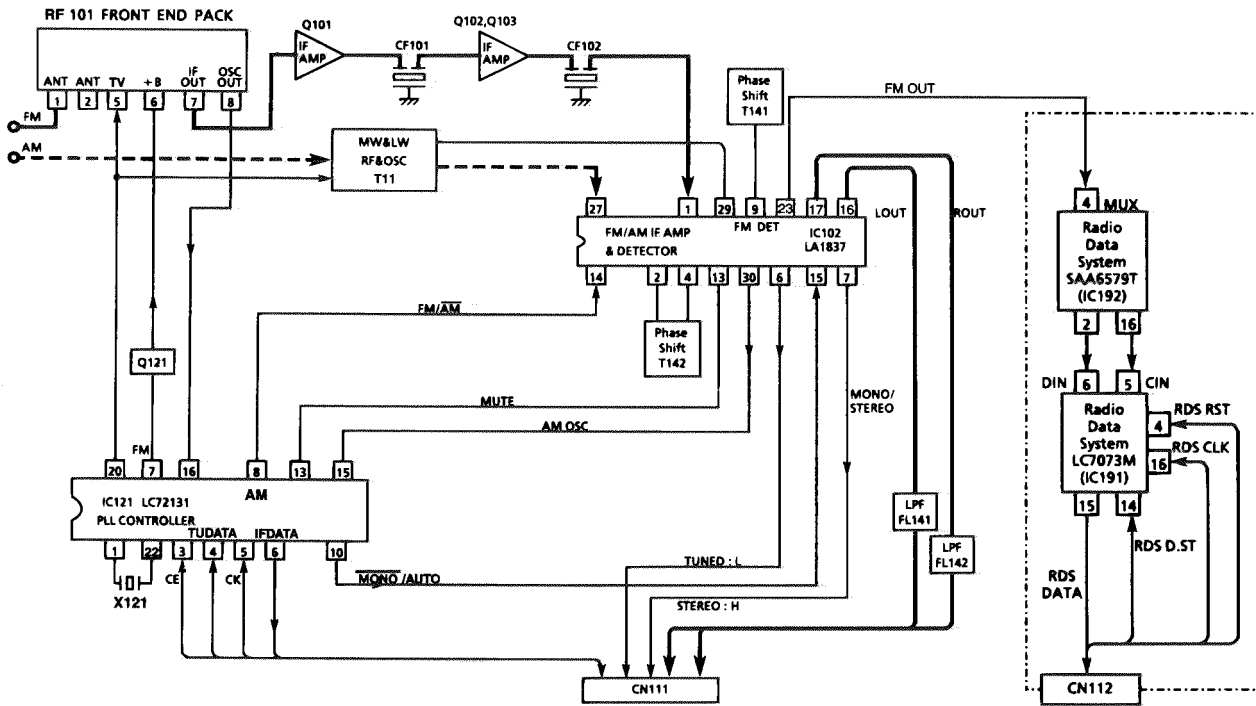

■ Power Supply Section

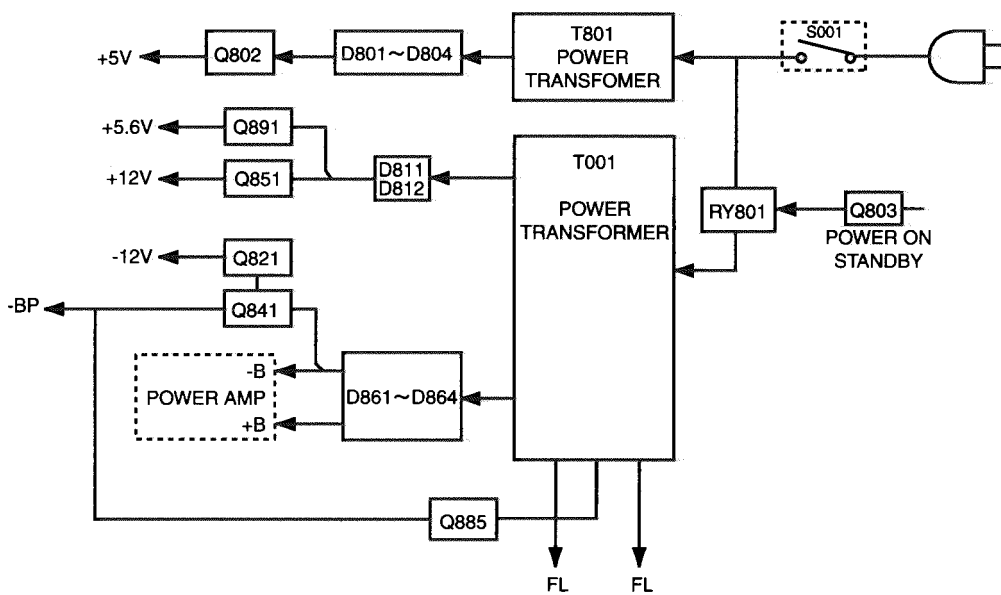

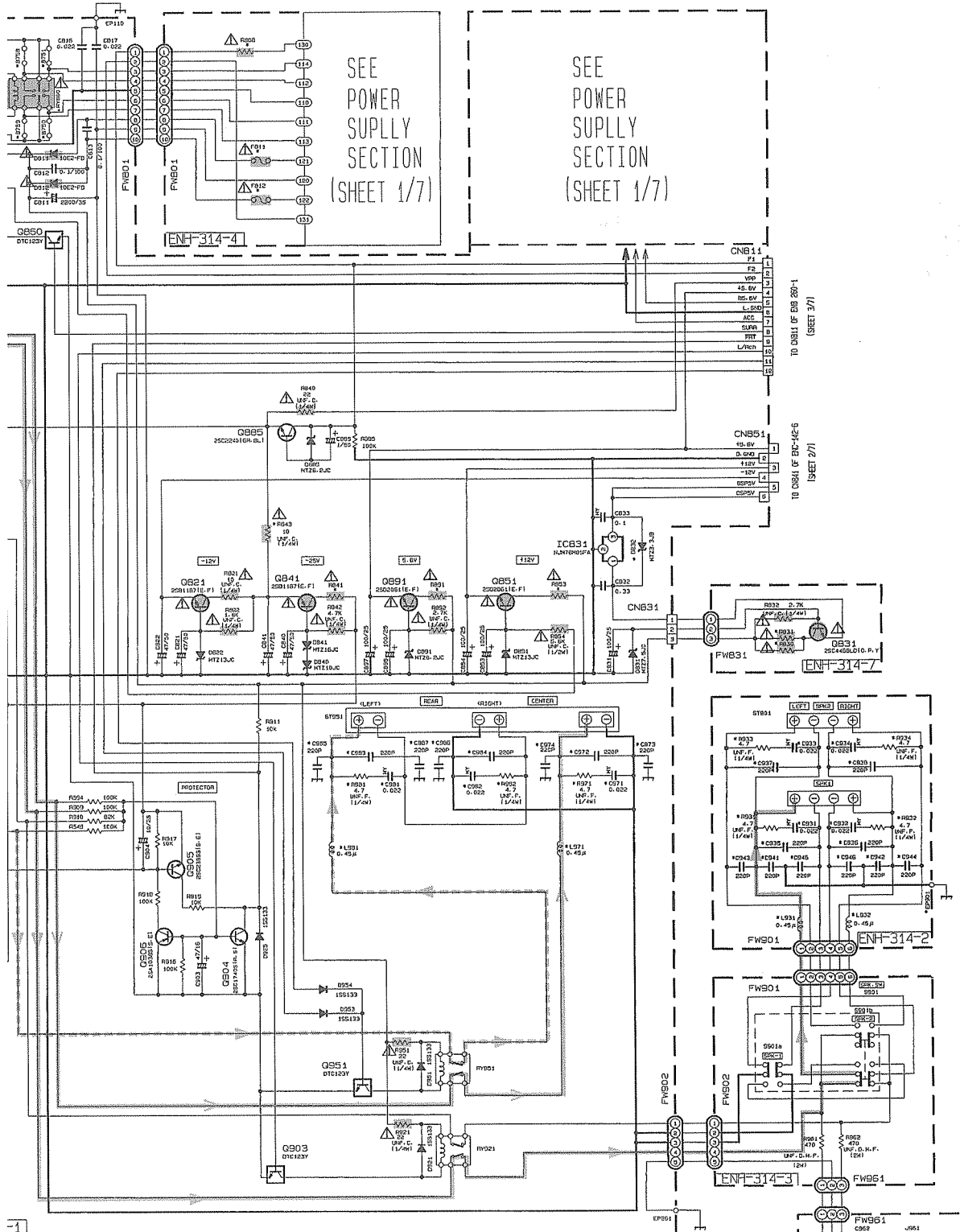

SEE POWER SUPPLY SECTION (SHEET 1/7)

SEE POWER SUPPLY SECTION (SHEET 1/7)

ENH-314-7

ENH-314-2

ENH-314-3

ENH-314-6

- ➔ MAIN SIGNAL
- ➔ CENTER SIGNAL
- ➔ REAR SIGNAL
- ➔ AM RADIO SIGNAL
- ➔ FM RADIO SIGNAL

⚠ Parts are safety assurance parts. When replacing those parts make sure to use the specified one.

POWER SUPPLY SECTION

5

4

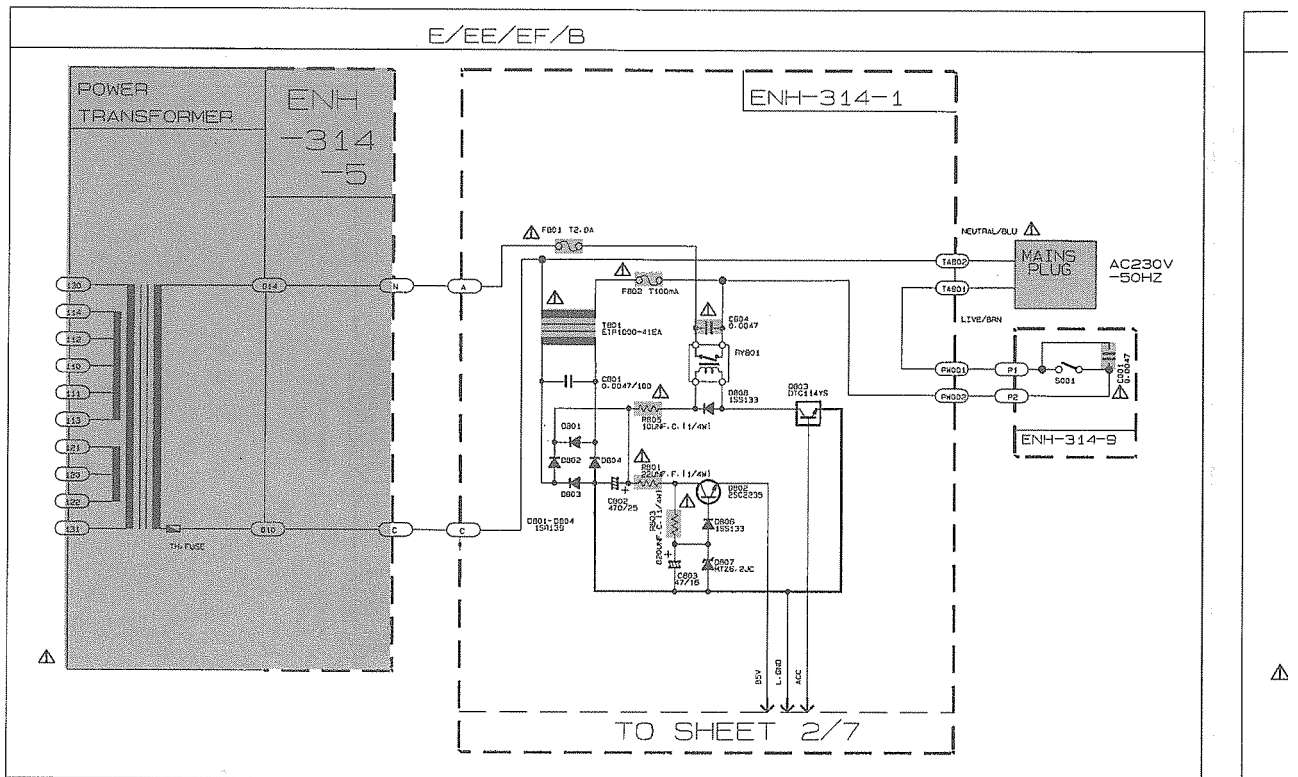

3

2

1

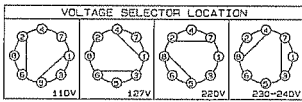
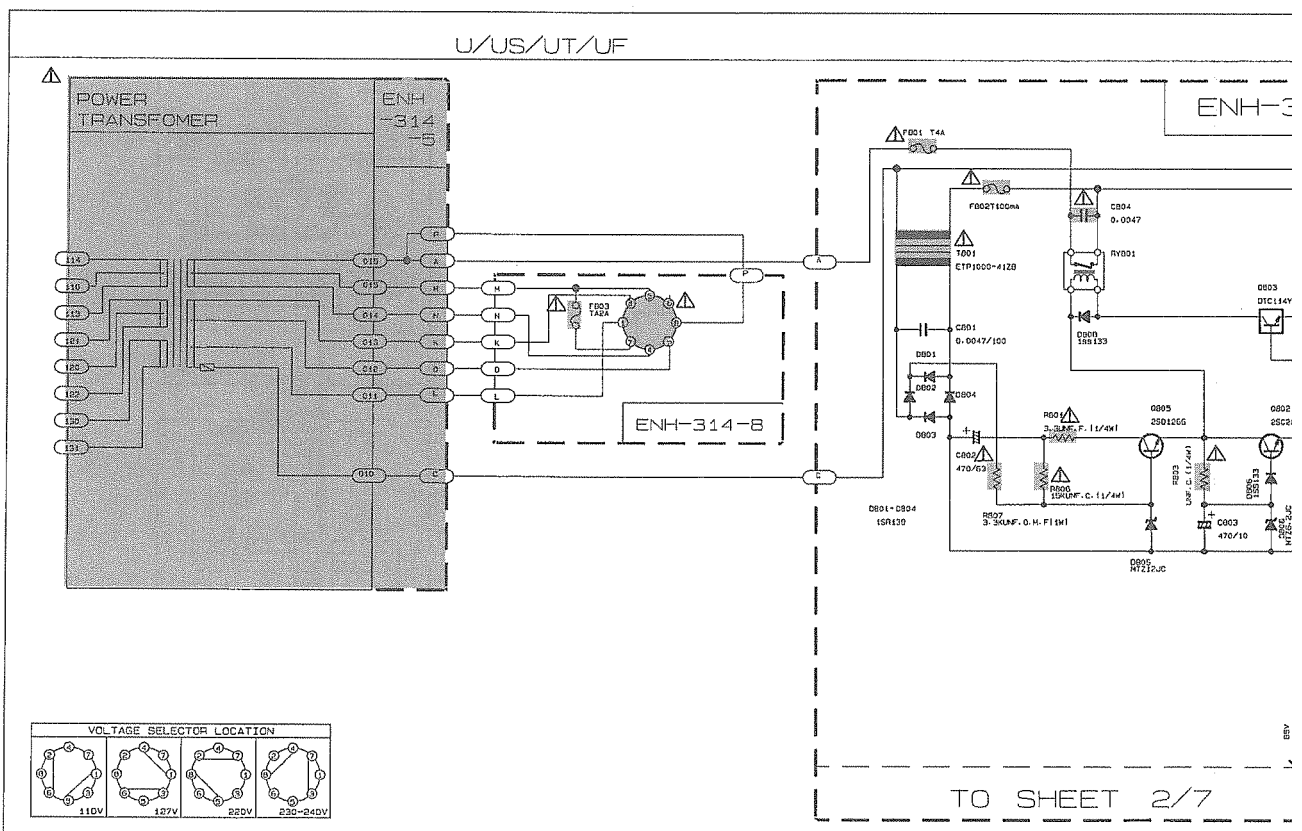

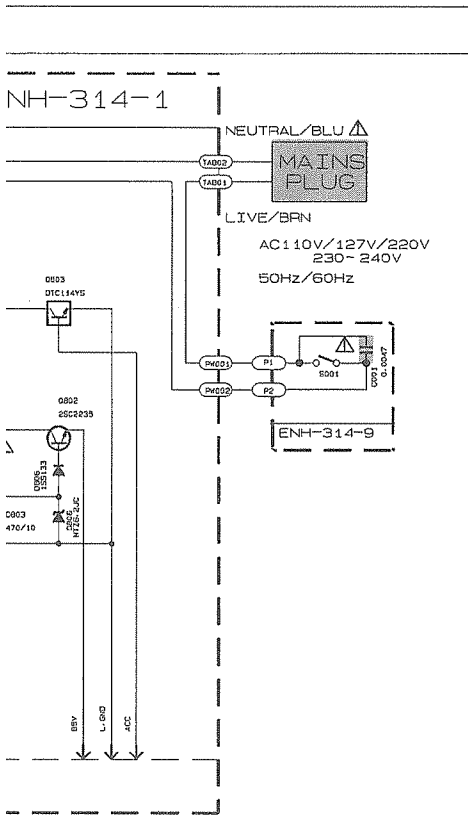
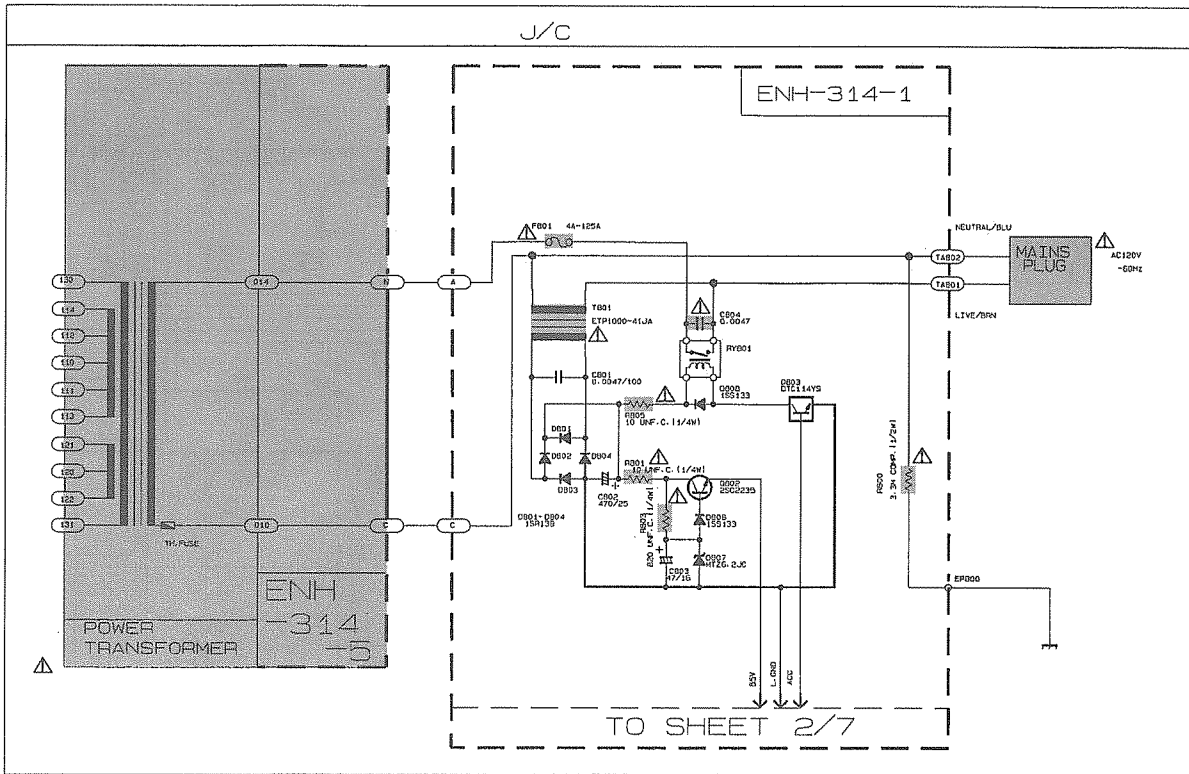

VERSION CODES

- EN: NORDIC COUNTRIES
- E: CONTINENTAL EUROPE
- EE: EASTERN EUROPE
- B: U. K.
- C: CANADA
- J: U. S. A.
- US: SINGAPORE
- UT: TAIWAN
- UF: CHINA
- U: UNIVERSAL EXCEPT ALL OF ABOVE

NOTES:

MARK(*) IS TO SHOW DEVIATION IN VERSIONS.
 DETAILS ARE EXPLAINED NEAR THE MARK.

EXPLANATION OF OVERALL OF SCHEMA.

MODEL RX-554VBK/RX-554RBK

SHEET NUMBER	CIRCUIT DESCRIPTION
1/7	PRIMARY
2/7	RECTIFIER/REGULATOR /AUDIO AMP./SPEAKER TERMINAL
3/7	AUDIO VIDEO SIGNAL INPUT TERMINAL /SOURCE SELECT IC /FRONT REAR CENTER VOLUME
4/7	USER CONTROL KEYS/SYSTEM CONTROL LSI /FL DISPLAY/SURROUND IC.
5/7	TUNER (ONLY C J)
6/7	TUNER (ONLY EN E EE B)
7/7	TUNER (ONLY US UT U UF)

⚠ Parts are safety assurance parts.
 When replacing those parts make
 sure to use the specified one.

■ AUDIO / VIDEO SIGNAL INPUT SECTION

5

4

3

2

1

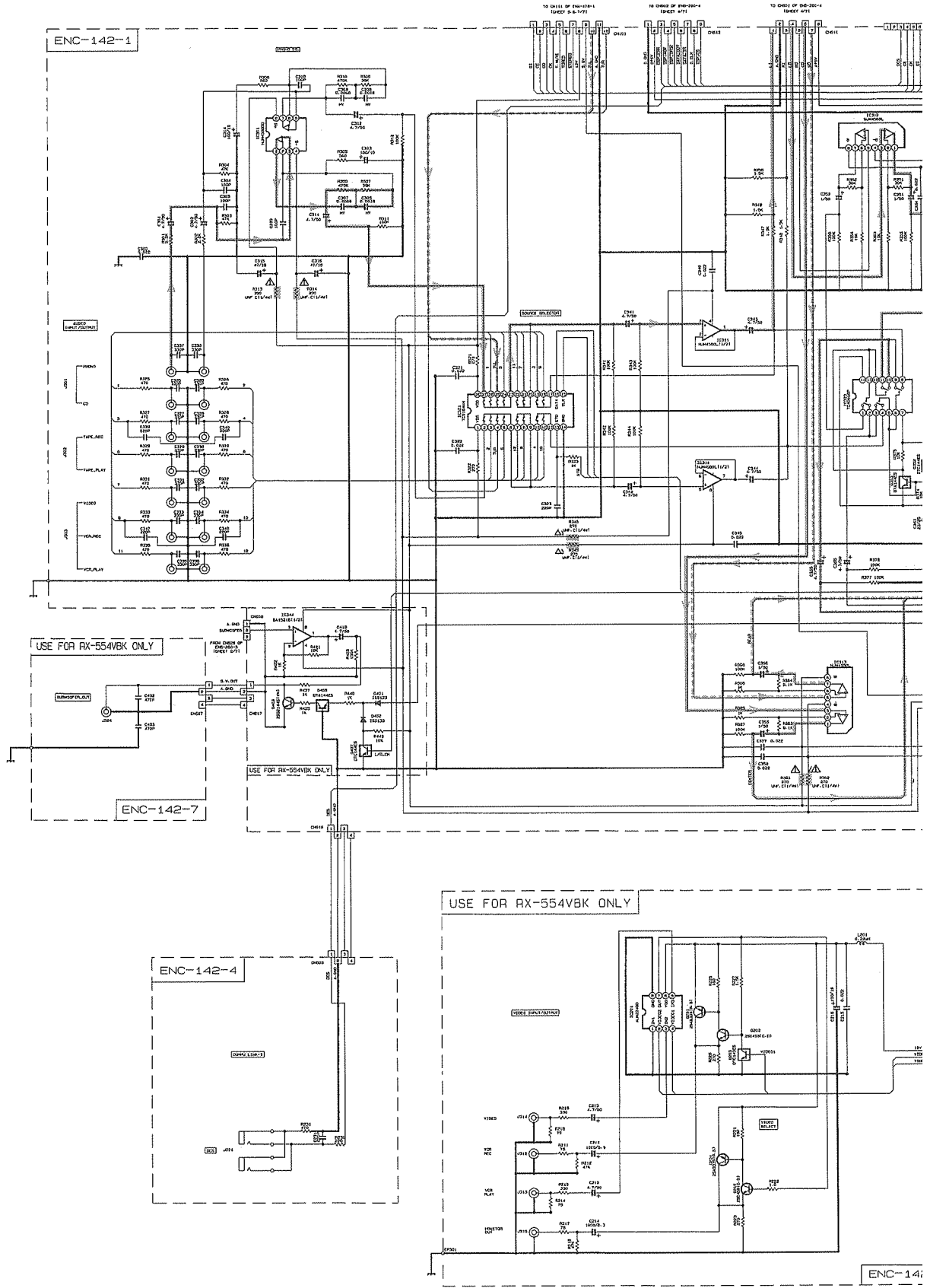

A

B

C

D

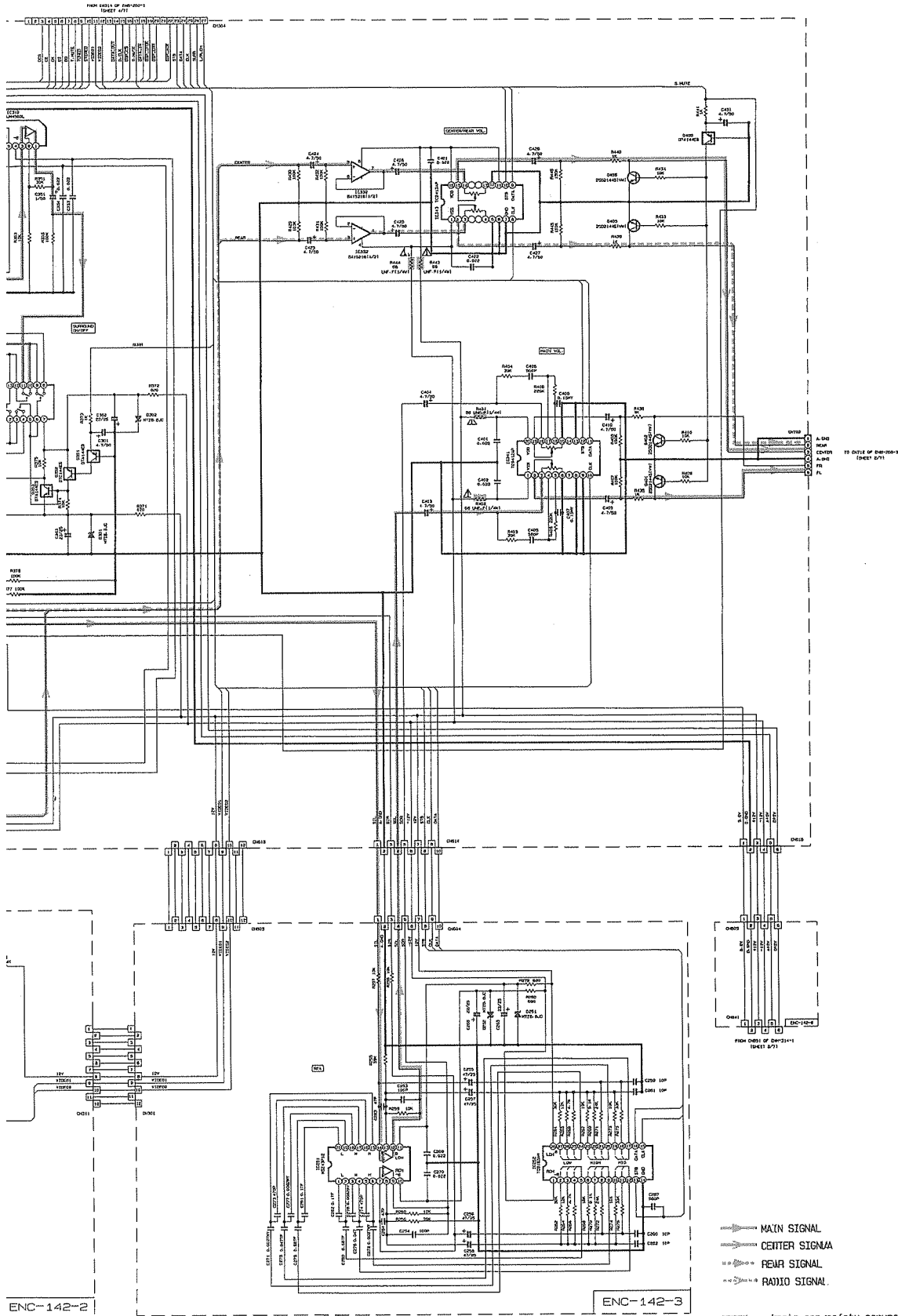

- ➔ MAIN SIGNAL
- ➔ CENTER SIGNAL
- ➔ FEAR SIGNAL
- ➔ RADIO SIGNAL

⚠ (s)rts are safety assurance parts. When replacing thos; parts make sure to use the specified on..

SYSTEM CONTROL SECTION

5

4

3

2

1

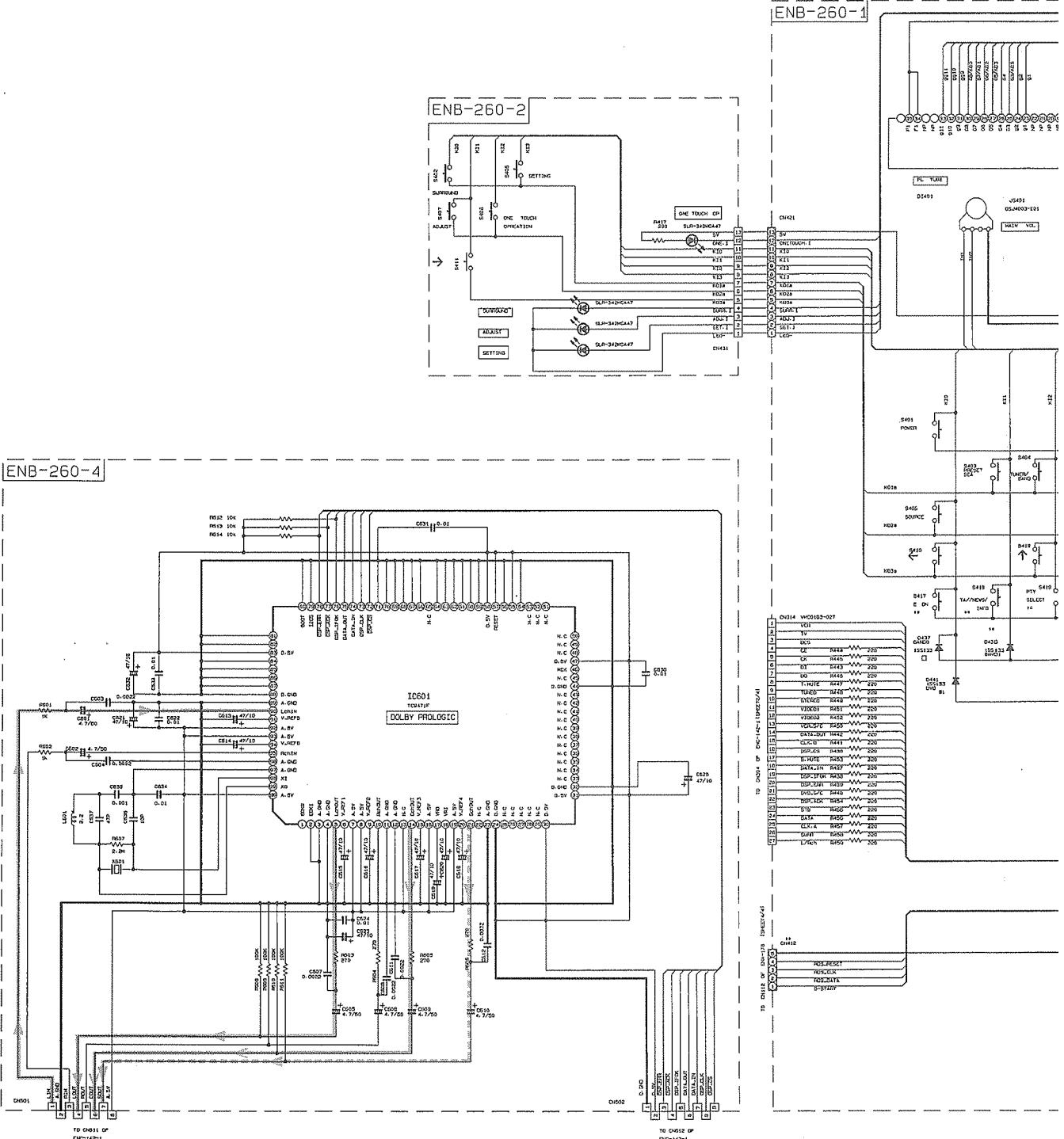

A

B

C

2-22

D

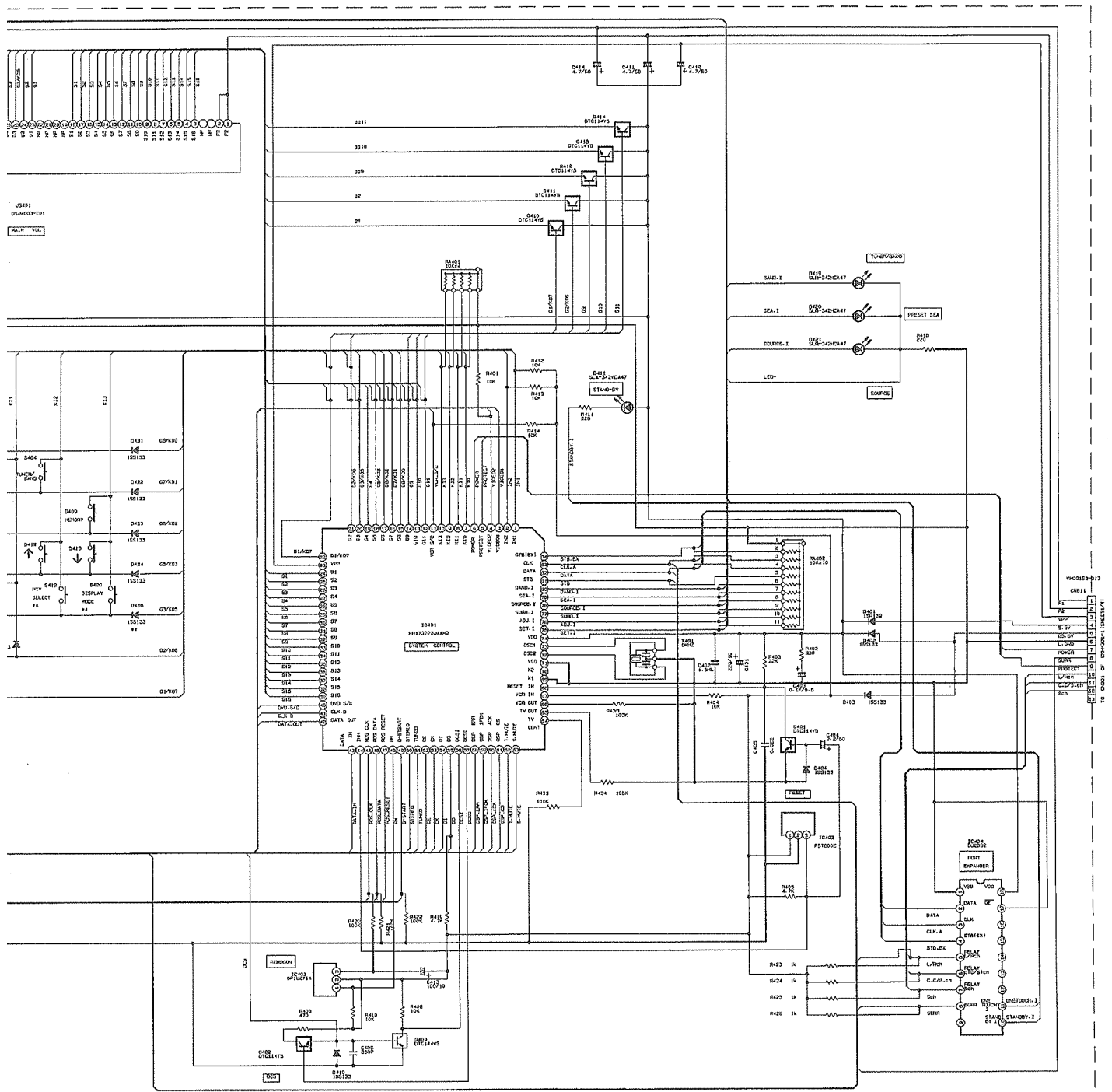

——— MAIN SIGNAL
 - - - - - CENTER SIGNAL
 ····· REAR SIGNAL

■ TUNER SECTION

FOR EF EN G. BS (WITH RDS)
ENA-17B

5

4

3

2

1

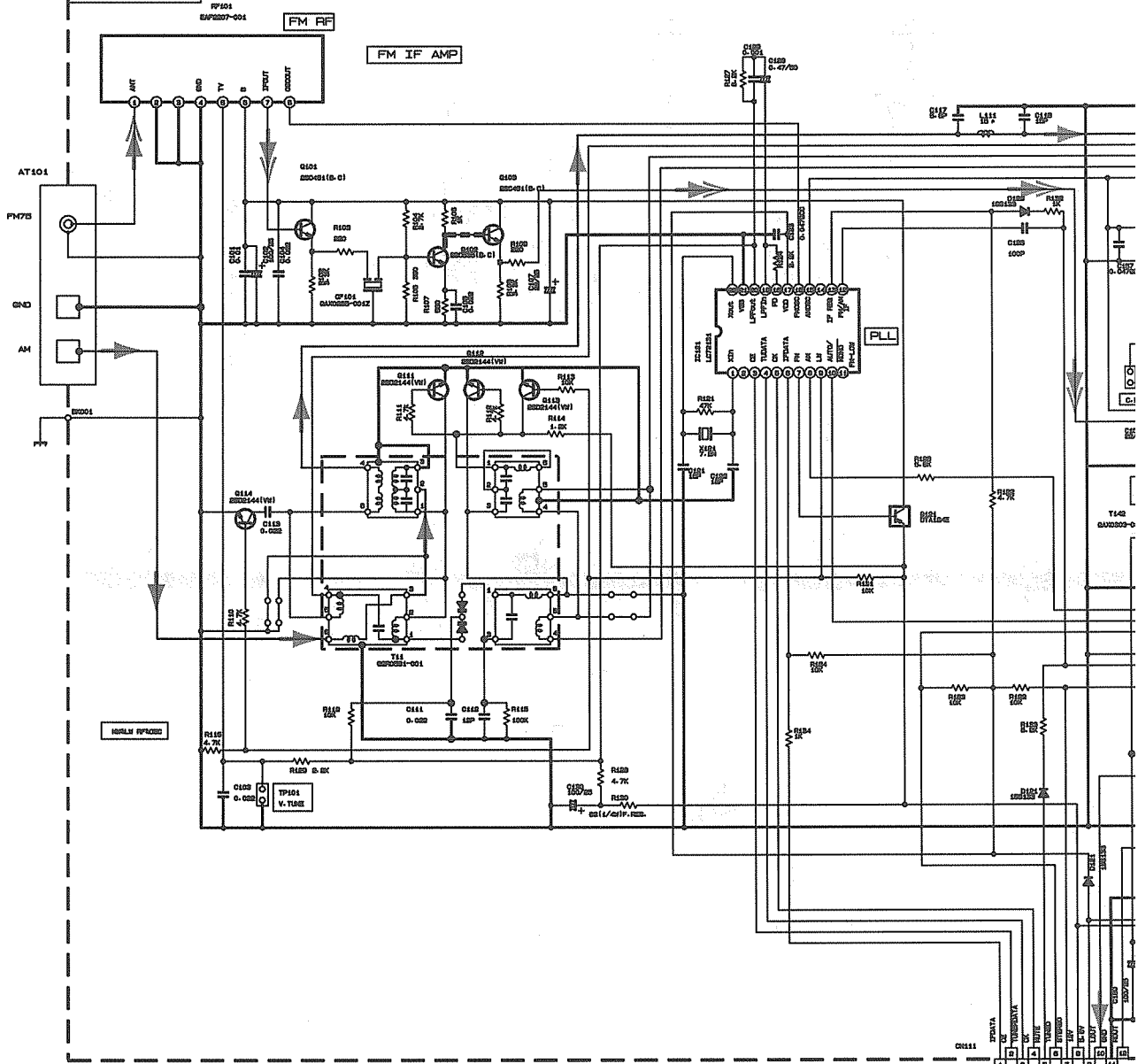

RE101
GAU005-001

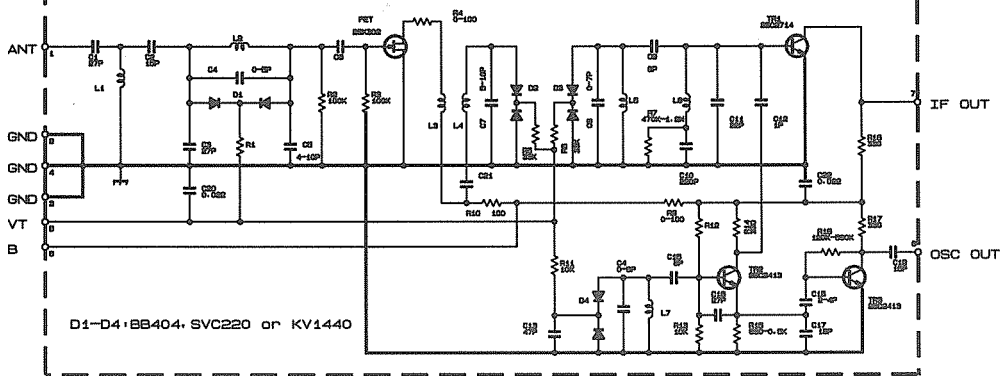

TO CN101 OF
ENC-14B-1
(SHEET 3/7)

Note : GRX554VBK/RBK(s/G)

A

B

C

D

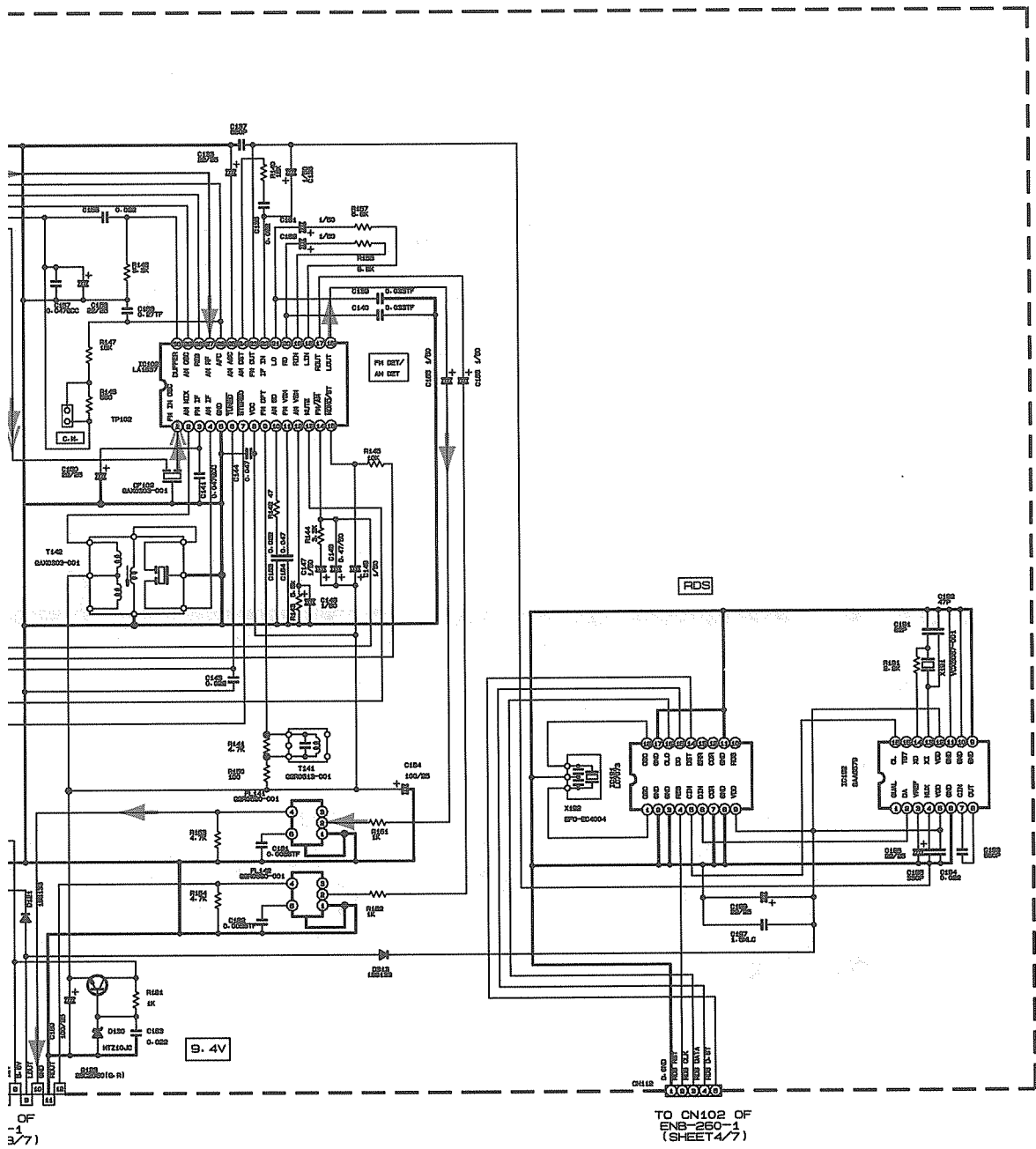

1 OF 3/7

TO CN102 OF EN3-250-11 (SHEET 4/7)

➔ AM/RADIO MAIN SIGNAL
➔ FM RADIO SIGNAL

■ MAIN AMP.P.C.Board

5
4
3
2
1

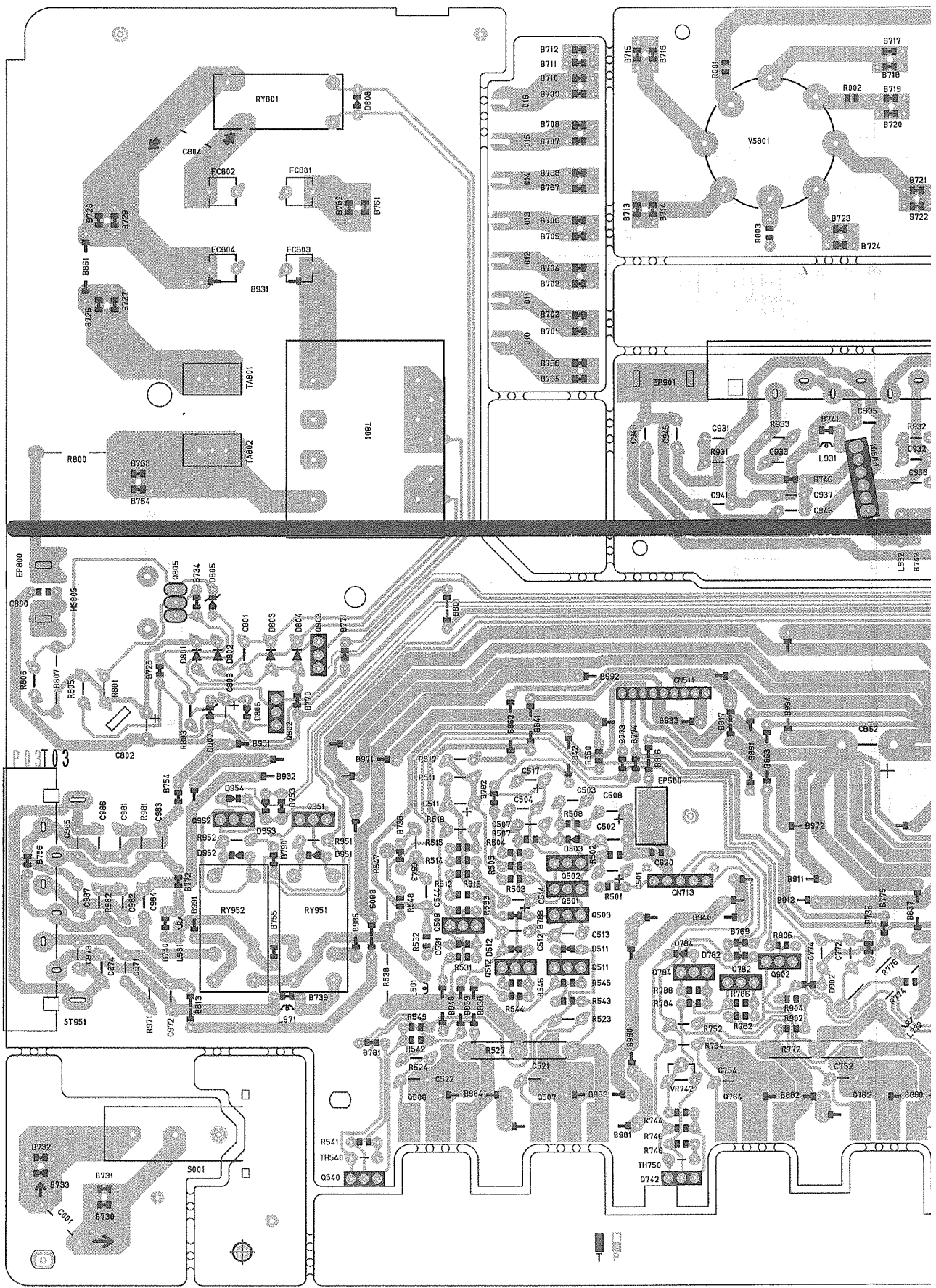

A B C 2-24 D

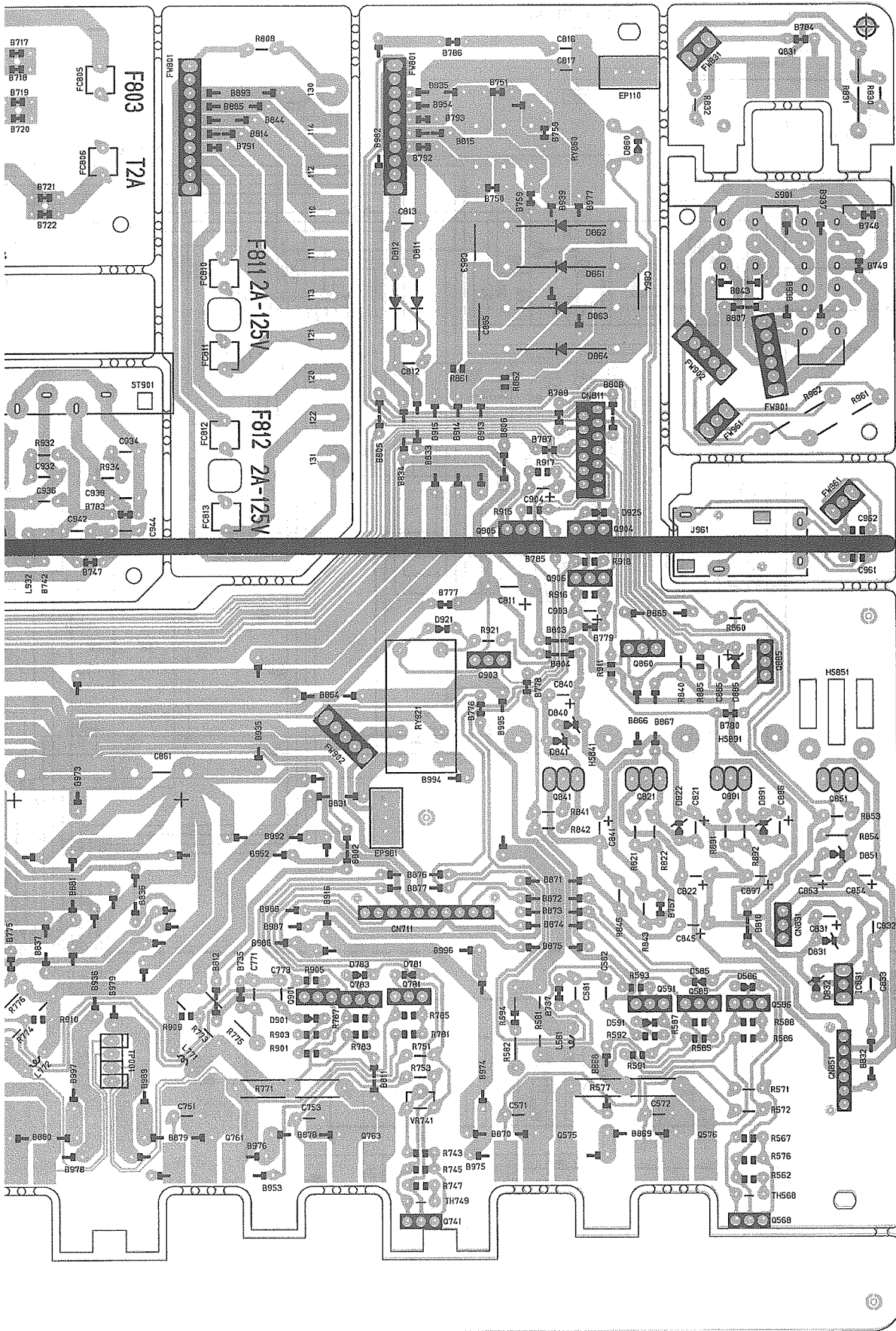

D | E | F | G | H

INPUT.PC.Board

5
4
3
2
1

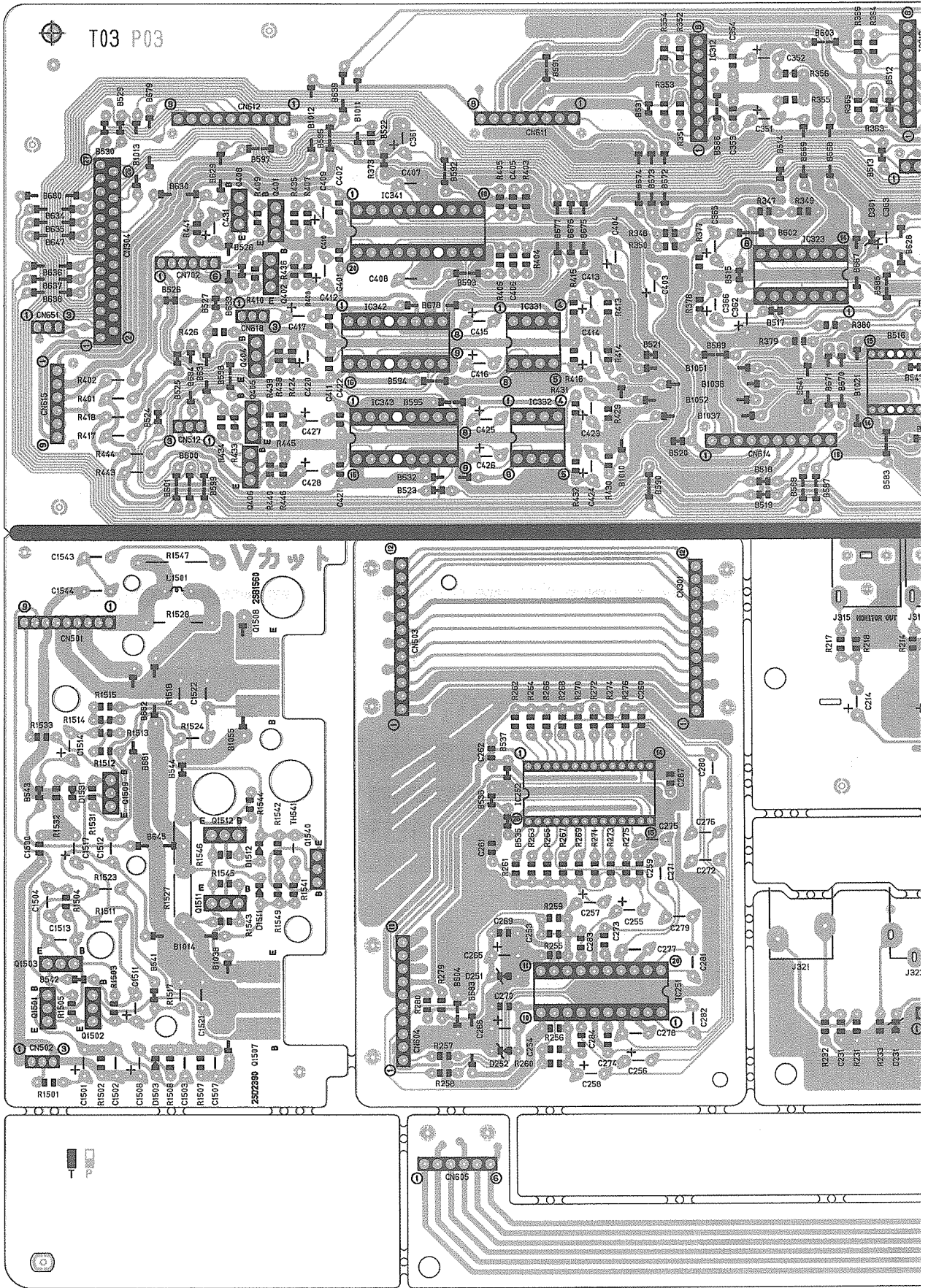

A B C D

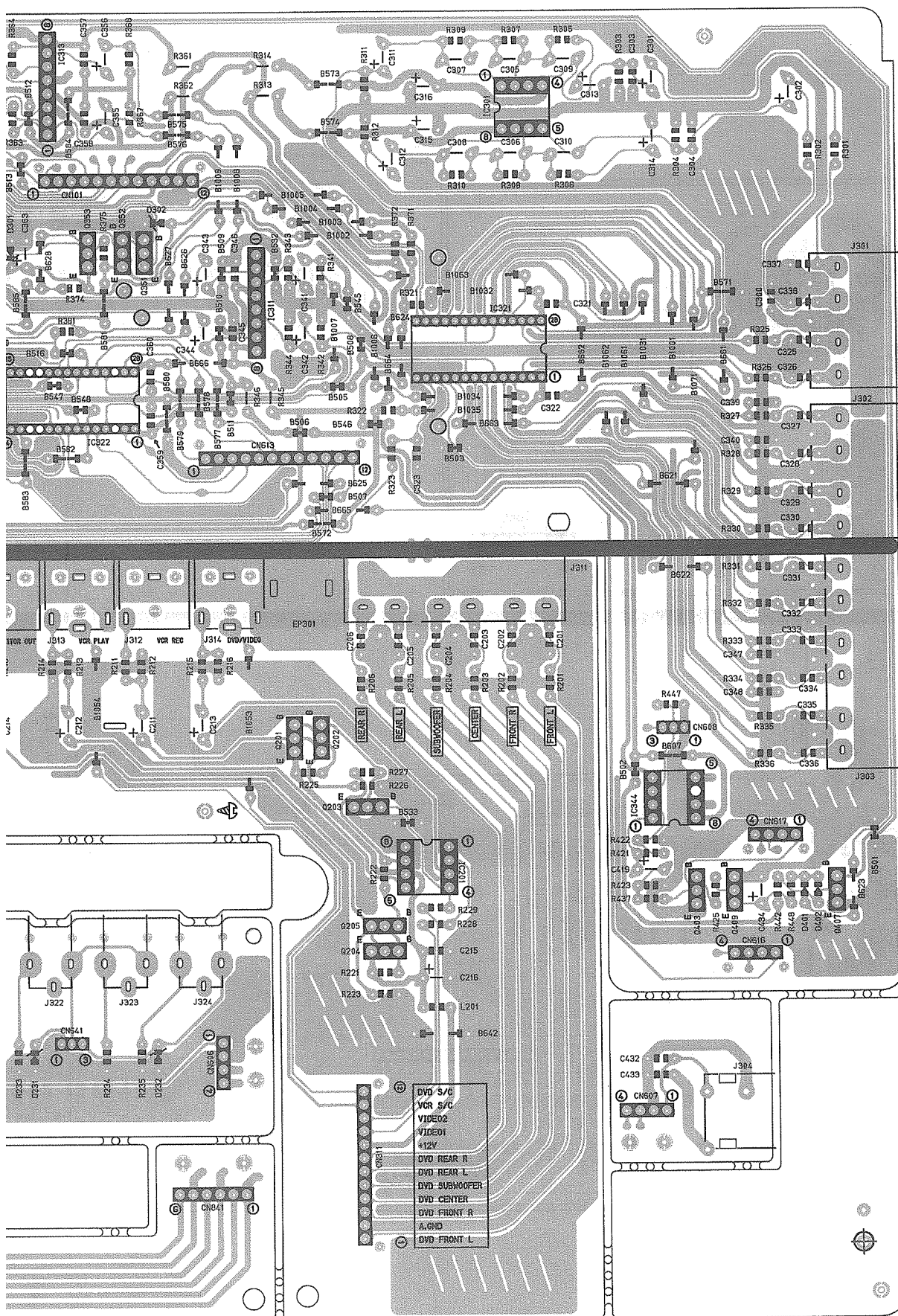

E

F

G

FRONT P.C.Board

5

4

3

2

1

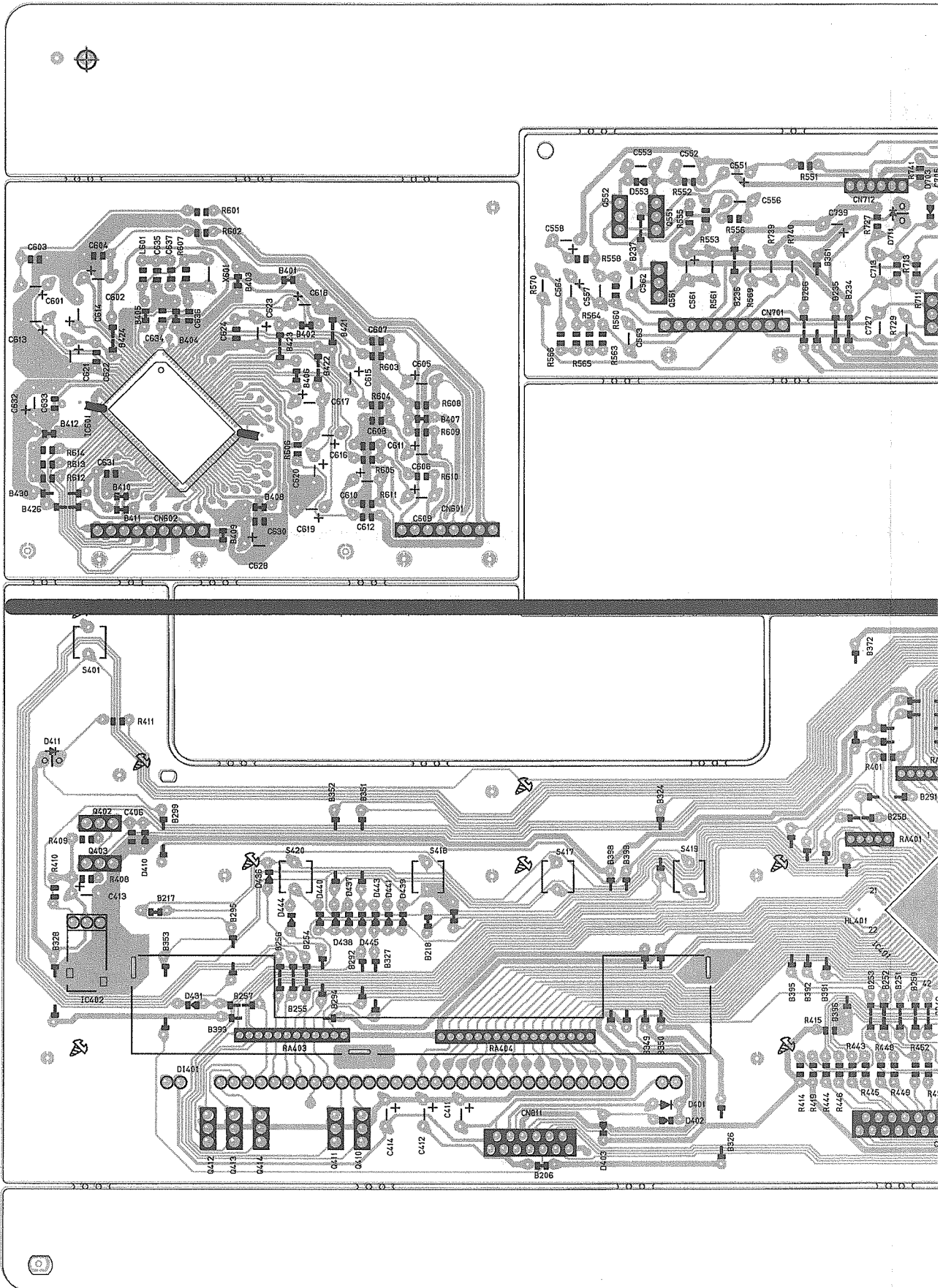

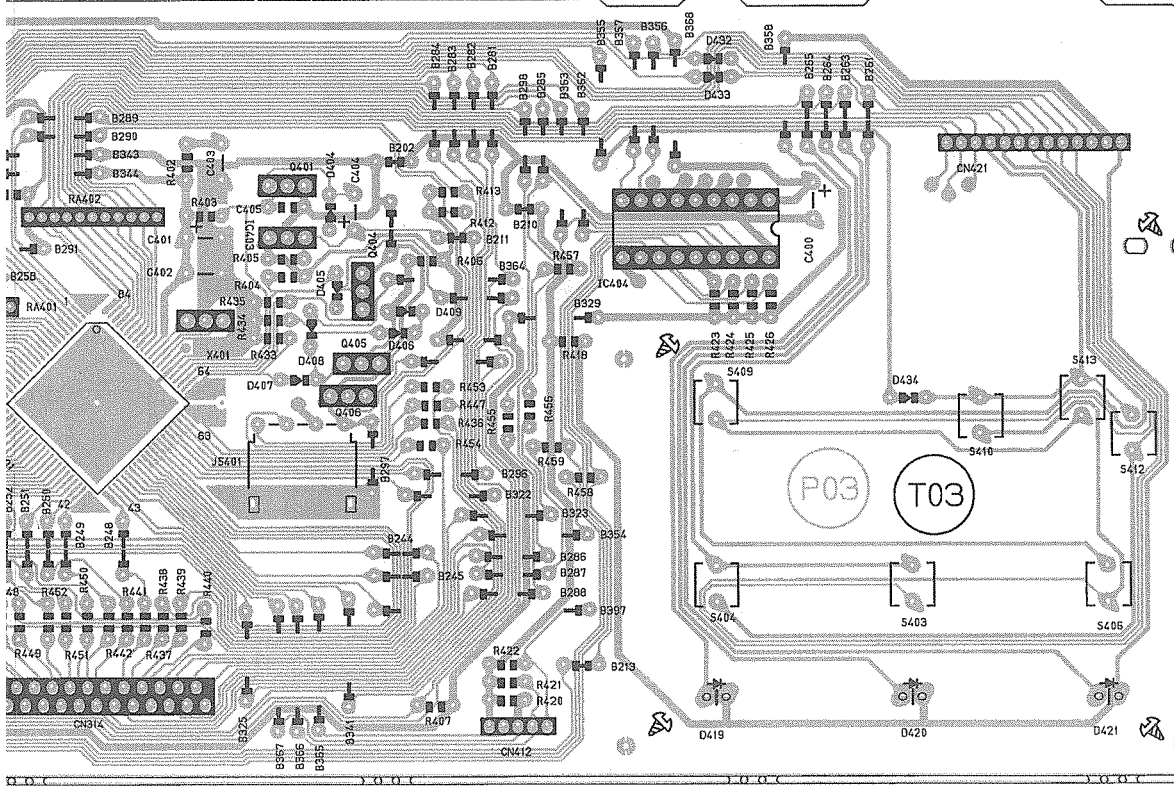
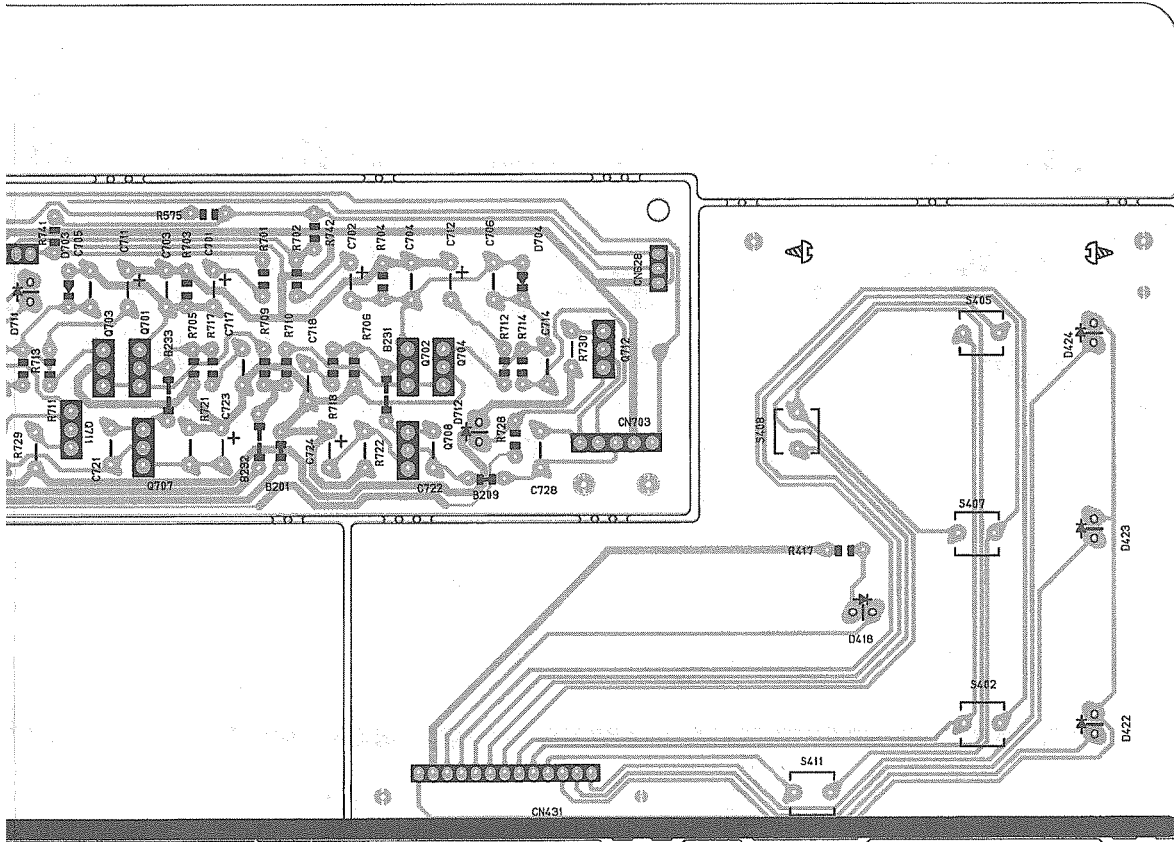

D | E | F | G | H

TUNER P.C.Board

5
4
3
2
1

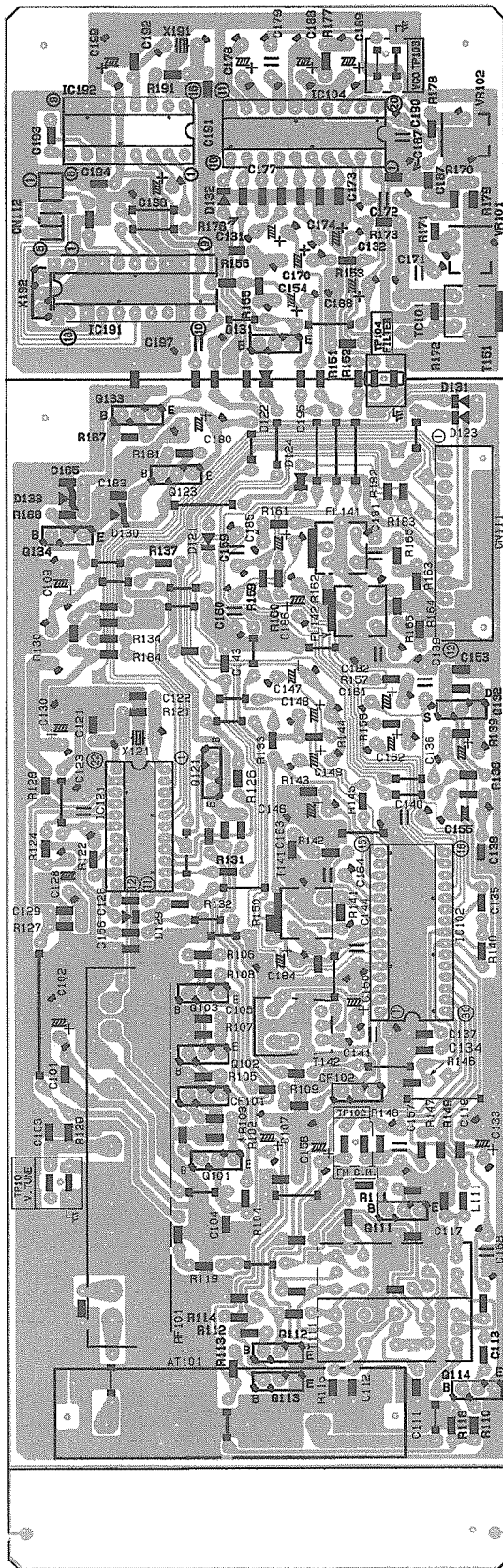

A

B

C

- MEMO -

PARTS LIST

[RX-554RBK]

* All printed circuit boards and its assemblies are not available as service parts.

The Marks for Designated Areas

B --- U.K.
 E --- Continental Europe
 EE -- East Europe
 EN -- North Europe

- Contents -

General Exploded View and Parts List	-----	3-2
Electrical Parts List	-----	3-4
Tuner P.C.B.	-----	3-4
Main P.C.B.	-----	3-4
Control P.C.B.	-----	3-7
Front P.C.B.	-----	3-9
Accessories List	-----	3-12
Packing Materials and Parts List	-----	3-13

RX554RBK

■ Parts List

Block No. M1MM

△	Item	Parts Number	Parts Name	Q'ty	Description	Area
	1	LE10079-013AKP	FRONT PANEL	1		
	2	LE30359-001A	POWER BUTTON	1		
	3	FSJD4001-002	INDICATOR LENS	1		
	4	LE20125-001A	PUSH BUTTON	1		
	5	LE40137-001A	INDICATOR LENS	7		
	6	LE30360-001A	PUSH BUTTON	1		
	8	QYSDSF2608Z	SCREW	13		
	9	QYSDSG3008M	SCREW	6		
	10	QYSBSG3008E	T. SCREW	32		
	11	LE10081-003A	CHASSIS BASE	1		
	12	LE20126-003A	FRONT BKT	1		
	13	LE30365-004A	BRACKET	1		
	14	E68587-223SM	P. W. BOARD BRACKET	2		
	15	QYSBST3006E	TAP. SCREW	6		
	16	LE40138-001A	GUIDE BRACKET	5		
	17	VJF4039-00MSM	FOOT ASSY	4		
	18	QYSBST3010Z	SCREW	4		
	19	E407321-002SM	PUSH BUTTON	3		
	20	LE40264-001A	PROTECTOR COVER	1		
	21	E310243-002	PLASTIC RIVET	1		
	22	LE40175-202A	PROTECTOR COVER	1		
	24	VKZ4150-001	NUT	1		
	25	VWF1227-30TTB	FLAT WIRE	1	FW304	
	26	E309840-005SM	HEAT SINK	1		
	27	E310171-001SM	HEAT SINK BRACKET	1		
	28	E310172-001SM	HEAT SINK BRACKET	1		
	29	LE40263-001A	PROTECTOR COVER	1		
	30	E73525-003	SCREW	9		
△	31	2SD2389LD/OPY/	SI. TRANSISTOR	4	Q761, Q762, Q507, Q575	
△	32	2SB1559LD/OPY/	SI. TRANSISTOR	4	Q763, Q764, Q508, Q576	
△	33	2SC4466LD/OPY/	SI. TRANSISTOR	1	Q831	
△	34	QQT0164-003	POWER TRANSFORMER	1		
	35	QYSDSTL4010E	SPECIAL SCREW	4		
	36	E406309-002	SPACER	4		
	37	LE20127-009AKP	REAR PANEL	1		B E EN
		LE20127-015AKP	REAR PANEL	1		EE
	38	QYSBSGY3008M	SPECIAL SCREW	16		
	39	QYSBST3006M	SCREW	2		
△	40	QMP39E0-200	POWER CORD	1		E EE EN
△		QMP5530-0085BS	POWER CORD	1		B
△	41	QHS3771-108	CORD STOPPER	1		
	42	LE20131-001A	METAL COVER	1		
	43	E406308-003	SPECIAL SCREW	4		
	44	LV30414-001A	M. VOL KNOB ASSY	1		
△	45	QMF51E2-2R0-J1	FUSE	1	F801	
△	46	QMF51A2-R10-S	FUSE	1	F802	
△	48	QMF51E2-2R0-J1	FUSE	2	F811, F812	
	50	E409530-001SM	P. W. BOARD HOLDER	1		
	51	E310243-002	PLASTIC RIVET	2		
	52	VWF1213-16TTB	FLAT WIRE	1	FW811	
	53	LV30384-001A	FASTENER	1		
	54	E409396-001	CAUTION LABEL	1		
	55	E307572-001	VINYL TIE	1		
	57	LE30361-001A	WINDOW SCREEN	1		
	58	VJD5429-001	JVC MARK	1		

General Exploded View and Parts List

Block No. M 1 M M

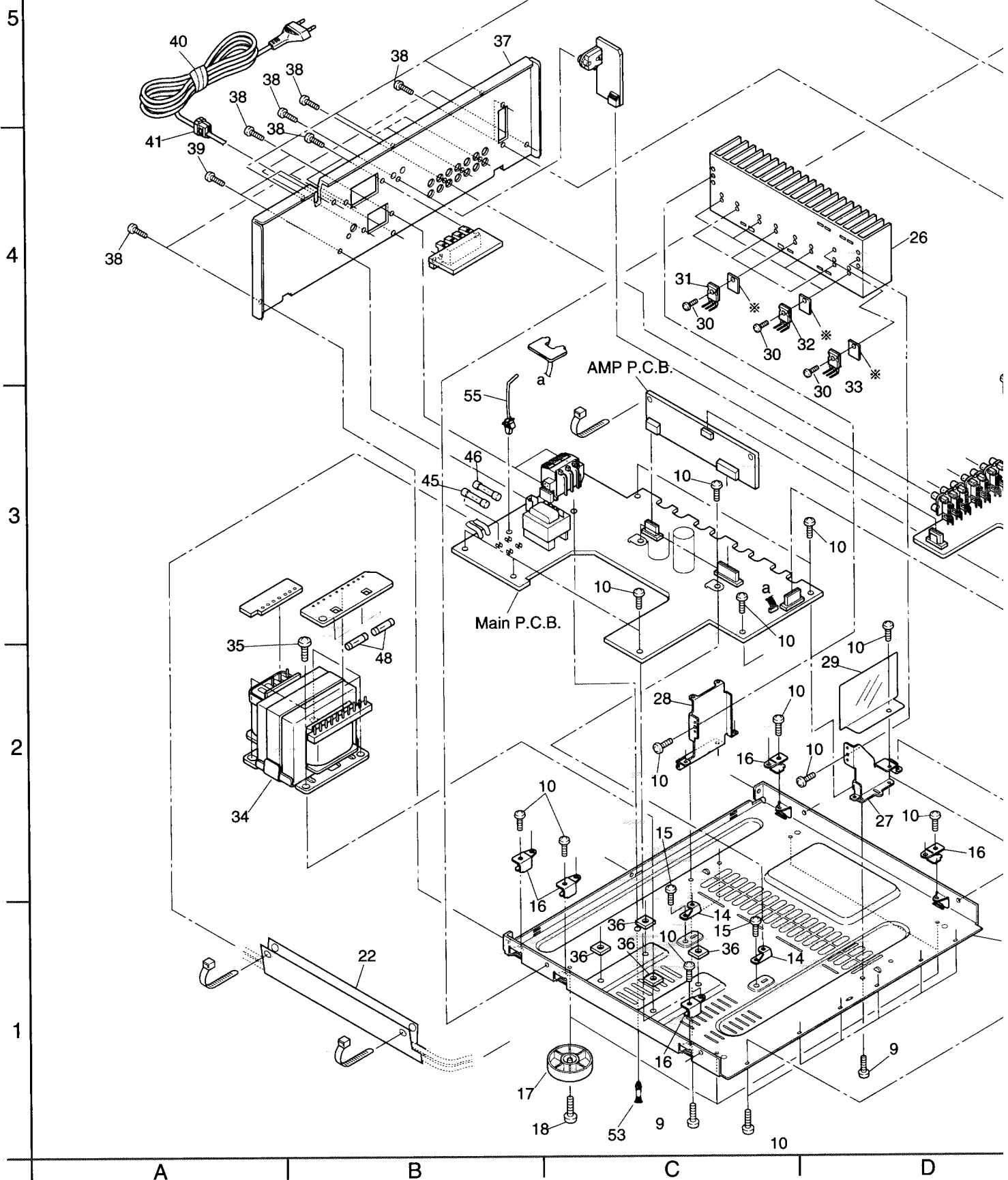

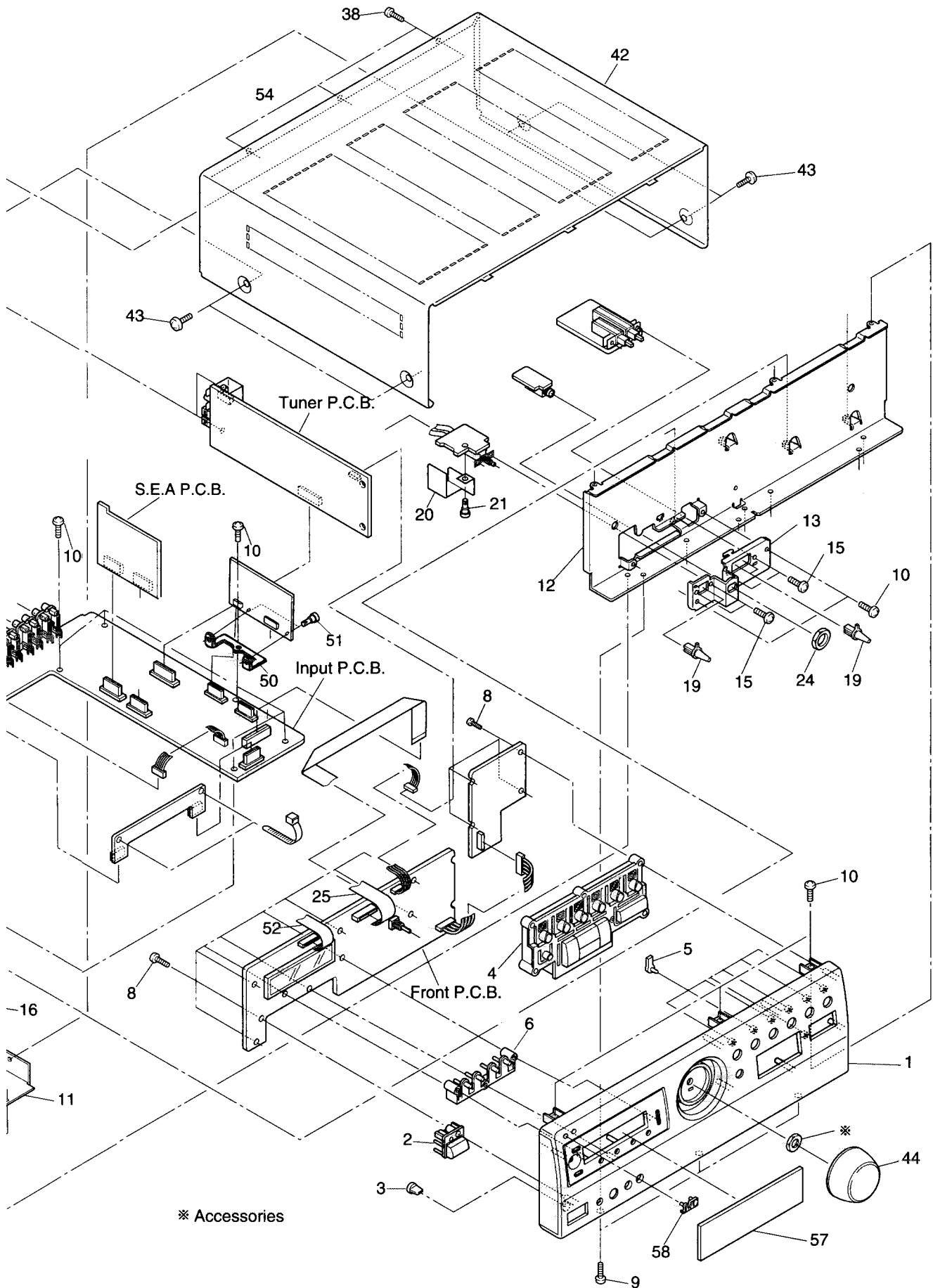

■Electrical Parts List (Tuner P.C.B.)

△	Item	Parts Number	Description	Area
		I. C. S		
	IC102	LA1837	I. C (MONO-ANALOG)	
	IC121	LC72131	I. C (M)	
	IC191	LC7073	I. C (DIGI-MOS)	
	IC192	SAA6579	I. C (M)	
		DIODES		
	D121	1SS133-T2	SI. DIODE	
	D123	1SS133-T2	SI. DIODE	
	D129	1SS133-T2	SI. DIODE	
	D130	MTZJ10C-T2	ZENER	
	D131	1SS133-T2	SI. DIODE	
		TRANSISTORS		
	Q101	2SC461/BC/-T	SILICON	
	Q102	2SC535/BC/-T	SILICON	
	Q103	2SC461/BC/-T	SILICON	
	Q111	2SD2144S/VW/-T	SILICON	
	Q112	2SD2144S/VW/-T	SILICON	
	Q113	2SD2144S/VW/-T	SILICON	
	Q114	2SD2144S/VW/-T	SILICON	
	Q121	DTA124ES-T	SILICON	
	Q123	2SC206D/OR/-T	SILICON	
		CAPACITORS		
	C101	QDYB1CM-103Y	0.01MF 16V C CAP.	
	C102	QETC1EM-107Z	100MF 25V AL E. CAP.	
	C103	QDVB1EZ-223Y	0.022MF 25V C CAP I M	
	C104	QDVB1EZ-223Y	0.022MF 25V C CAP I M	
	C105	QDVB1EZ-223Y	0.022MF 25V C CAP I M	
	C107	QETC1EM-226ZM	22MF 25V E. CAP.	
	C109	QETC1EM-226ZM	22MF 25V E. CAP.	
	C111	QDVB1EZ-223Y	0.022MF 25V C CAP I M	
	C112	QDCB1HJ-120Y	12PF 50V C CAP.	
	C113	QDVB1EZ-223Y	0.022MF 25V C CAP I M	
	C117	QCSB1HK-5R6Y	5.6PF 50V GER. CAP.	
	C118	QCSB1HJ-150Y	15PF 50V GER. CAP.	
	C121	QDCB1HJ-180Y	18PF 50V C. CAP.	
	C122	QDCB1HJ-180Y	18PF 50V C. CAP.	
	C123	QDX31EM-473Z	0.047MF 25V C CAP.	
	C126	QCSB1HK-101Y	100PF 50V GER. CAP.	
	C128	QENB1HM-474	0.47MF 50V NP E. CAP.	
	C129	QCSB1HK-102	1000PF 50V GER. CAP.	
	C130	QETC1EM-107Z	100MF 25V AL E. CAP.	
	C133	QETC1EM-226ZM	22MF 25V E. CAP.	
	C134	QCBB1HK-331Y	330PF 50V GER. CAP.	
	C135	QDVB1EZ-223Y	0.022MF 25V C CAP I M	
	C136	QETN1HM-105Z	1MF 50V AL E. CAP.	
	C137	QCBB1HK-391Y	390PF 50V GER. CAP.	
	C139	QFLB1HJ-473	0.047MF 50V MYLAR CAP.	
	C140	QFLB1HJ-473	0.047MF 50V MYLAR CAP.	
	C141	QDX31EM-473Z	0.047MF 25V C CAP.	
	C143	QDVB1EZ-223Y	0.022MF 25V C CAP I M	
	C144	QDX31EM-473Z	0.047MF 25V C CAP.	
	C146	QETN1HM-105Z	1MF 50V AL E. CAP.	
	C147	QETN1HM-105Z	1MF 50V AL E. CAP.	
	C148	QETN1HM-474Z	0.47MF 50V AL E. CAP.	
	C149	QETN1HM-105Z	1MF 50V AL E. CAP.	
	C150	QETC1EM-226ZM	22MF 25V E. CAP.	
	C156	QDVB1EZ-223Y	0.022MF 25V C CAP I M	
	C157	QDX31EM-473Z	0.047MF 25V C CAP.	
	C158	QETC1EM-226ZM	22MF 25V E. CAP.	
	C161	QETN1HM-105Z	1MF 50V AL E. CAP.	
	C162	QETN1HM-105Z	1MF 50V AL E. CAP.	
	C163	QDVB1EZ-223Y	0.022MF 25V C CAP I M	
	C164	QDX31EM-473Z	0.047MF 25V C CAP.	
	C168	QFVJ1HJ-274Z	0.27MF 50V T. FILM	
	C180	QETC1EM-107Z	100MF 25V AL E. CAP.	
	C181	QFLB1HJ-562	5600PF 50V MYLAR CAP.	
	C182	QFLB1HJ-562	5600PF 50V MYLAR CAP.	
	C183	QDVB1EZ-223Y	0.022MF 25V C CAP I M	
	C184	QETC1EM-107Z	100MF 25V AL E. CAP.	
	C185	QETN1HM-105Z	1MF 50V AL E. CAP.	
	C186	QETN1HM-105Z	1MF 50V AL E. CAP.	
	C191	QCBB1HK-820Y	82PF 50V GER. CAP.	
	C192	QCSB1HJ-470	47PF 50V GER. CAP.	
	C193	QCBB1HK-561Y	560PF 50V GER. CAP.	
	C194	QDVB1EZ-223Y	0.022MF 25V C CAP I M	

△	Item	Parts Number	Description	Area
	C195	QCBB1HK-331Y	330PF 50V GER. CAP.	
	C196	QETC1EM-226ZM	22MF 25V E. CAP.	
	C197	QCZ0205-155	1.5MF 25V C. CAP.	
	C199	QETC1EM-226ZM	22MF 25V E. CAP.	
		RESISTORS		
	R102	QRE141J-332Y	3.3K 1/4W R. NETWORK	
	R103	QRE141J-221Y	220 1/4W R. NETWORK	
	R104	QRE141J-272Y	2.7K 1/4W R. NETWORK	
	R105	QRE141J-391Y	390 1/4W R. NETWORK	
	R106	QRE141J-102Y	1K 1/4W R. NETWORK	
	R107	QRE141J-561Y	560 1/4W R. NETWORK	
	R108	QRE141J-332Y	3.3K 1/4W R. NETWORK	
	R109	QRE141J-221Y	220 1/4W R. NETWORK	
	R110	QRE141J-472Y	4.7K 1/4W R. NETWORK	
	R111	QRE141J-472Y	4.7K 1/4W R. NETWORK	
	R112	QRE141J-472Y	4.7K 1/4W R. NETWORK	
	R113	QRE141J-103Y	10K 1/4W R. NETWORK	
	R114	QRE141J-122Y	1.2K 1/4W R. NETWORK	
	R115	QRE141J-104Y	100K 1/4W R. NETWORK	
	R116	QRE141J-472Y	4.7K 1/4W R. NETWORK	
	R119	QRE141J-103Y	10K 1/4W R. NETWORK	
	R121	QRE141J-473Y	47K 1/4W R. NETWORK	
	R122	QRE141J-472Y	4.7K 1/4W R. NETWORK	
	R124	QRE141J-222Y	2.2K 1/4W R. NETWORK	
	R126	QRE141J-562Y	5.6K 1/4W R. NETWORK	
	R127	QRE141J-822Y	8.2K 1/4W R. NETWORK	
	R128	QRE141J-472Y	4.7K 1/4W R. NETWORK	
	R129	QRE141J-222Y	2.2K 1/4W R. NETWORK	
	R130	QRZ9005-680X	68 FUSIBLE	
	R131	QRE141J-103Y	10K 1/4W R. NETWORK	
	R132	QRE141J-102Y	1K 1/4W R. NETWORK	
	R133	QRE141J-822Y	8.2K 1/4W R. NETWORK	
	R134	QRE141J-102Y	1K 1/4W R. NETWORK	
	R140	QRE141J-563Y	56K 1/4W R. NETWORK	
	R141	QRE141J-472Y	4.7K 1/4W R. NETWORK	
	R142	QRE141J-470Y	47 1/4W R. NETWORK	
	R143	QRE141J-562Y	5.6K 1/4W R. NETWORK	
	R144	QRE141J-332Y	3.3K 1/4W R. NETWORK	
	R145	QRE141J-103Y	10K 1/4W R. NETWORK	
	R146	QRE141J-562Y	5.6K 1/4W R. NETWORK	
	R147	QRE141J-273Y	27K 1/4W R. NETWORK	
	R148	QRE141J-561Y	560 1/4W R. NETWORK	
	R150	QRE141J-101Y	100 1/4W R. NETWORK	
	R157	QRE141J-182Y	1.8K 1/4W R. NETWORK	
	R158	QRE141J-182Y	1.8K 1/4W R. NETWORK	
	R161	QRE141J-102Y	1K 1/4W R. NETWORK	
	R162	QRE141J-102Y	1K 1/4W R. NETWORK	
	R163	QRE141J-472Y	4.7K 1/4W R. NETWORK	
	R164	QRE141J-472Y	4.7K 1/4W R. NETWORK	
	R181	QRE141J-102Y	1K 1/4W R. NETWORK	
	R182	QRE141J-103Y	10K 1/4W R. NETWORK	
	R183	QRE141J-103Y	10K 1/4W R. NETWORK	
	R184	QRE141J-103Y	10K 1/4W R. NETWORK	
	R191	QRE141J-222Y	2.2K 1/4W R. NETWORK	
		OTHERS		
	L111	QGL231K-150Y	INDUCTOR 1. M	
	T111	QGR0591-001	RF COIL	
	T141	QGR0613-001	I. F. TRANSFORMER	
	T142	QAX0303-001	CERAMIC FILTER	
	X121	QAX0259-001Z	RESONATOR 1. M	
	X191	QAX0263-001Z	CRYSTAL	
	X192	QAX0248-001Z	CERA LOCK	
	AT101	QNB0014-001	ANT TERMINAL	
	BK001	E308963-223SM	SHIELD BRACKET	
	CF101	QAX0285-001Z	CERAMIC FILTER	
	CF102	QAX0285-001Z	CERAMIC FILTER	
	CN111	QGB2510K1-12	CONNECTOR	
	CN112	QGA2001C1-05	5P PLUG ASSY	
	FL141	QGR0590-001	LOWPASS FILTER	
	FL142	QGR0590-001	LOWPASS FILTER	
	RF101	QAU0005-001	FRONT END	

■ Electrical Parts List (Main P.C.B.)

△	Item	Parts Number	Description	Area
		I. C. S		
△	10831	NUM78M05FA	I. C (MONO-ANALOG)	
		DIODES		
	D503	1SS133-T2	SI. DIODE	
	D511	1SS133-T2	SI. DIODE	
	D512	1SS133-T2	SI. DIODE	
	D531	1SS133-T2	SI. DIODE	
	D585	1SS133-T2	SI. DIODE	
	D586	1SS133-T2	SI. DIODE	
	D591	1SS133-T2	SI. DIODE	
	D781	1SS133-T2	SI. DIODE	
	D782	1SS133-T2	SI. DIODE	
	D783	1SS133-T2	SI. DIODE	
	D784	1SS133-T2	SI. DIODE	
	D801	1SR139-200-T4	SILICON	
	D802	1SR139-200-T4	SILICON	
	D803	1SR139-200-T4	SILICON	
	D804	1SR139-200-T4	SILICON	
	D806	1SS133-T2	SI. DIODE	
	D807	MTZJ6. 2C-T2	ZENER	
	D808	1SS133-T2	SI. DIODE	
△	D811	10E2-FD	DIODE	
△	D812	10E2-FD	DIODE	
	D822	MTZJ13C-T2	ZENER	
	D831	MTZJ7. 5C-T2	ZENER	
	D832	MTZJ3. 3B-T2	ZENER	
	D840	MTZJ10C-T2	ZENER	
	D841	MTZJ16C-T2	ZENER	
	D851	MTZJ13C-T2	ZENER	
	D860	1SS133-T2	SI. DIODE	
△	D861	30DF2-FC	SILICON	
△	D862	30DF2-FC	SILICON	
△	D863	30DF2-FC	SILICON	
△	D864	30DF2-FC	SILICON	
	D885	MTZJ6. 2C-T2	ZENER	
	D891	MTZJ6. 2C-T2	ZENER	
	D901	1SS133-T2	SI. DIODE	
	D902	1SS133-T2	SI. DIODE	
	D921	1SS133-T2	SI. DIODE	
	D925	1SS133-T2	SI. DIODE	
	D951	1SS133-T2	SI. DIODE	
	D953	1SS133-T2	SI. DIODE	
	D954	1SS133-T2	SI. DIODE	
		TRANSISTORS		
	Q501	2SC2240/L/-T	SILICON	
	Q502	2SC2240/L/-T	SILICON	
	Q503	2SA1038S/SE/-T	SILICON	
	Q509	2SA1038S/SE/-T	SILICON	
	Q511	2SC2389S/SE/-T	SI. TRANSISTOR	
	Q512	2SA1038S/SE/-T	SILICON	
	Q540	2SD636/QR/	SILICON	
	Q568	2SD636/QR/	SILICON	
	Q585	2SC2389S/SE/-T	SI. TRANSISTOR	
	Q586	2SA1038S/SE/-T	SILICON	
	Q591	2SA1038S/SE/-T	SILICON	
	Q741	2SD636/QR/	SILICON	
	Q742	2SD636/QR/	SILICON	
	Q781	2SC2389S/SE/-T	SI. TRANSISTOR	
	Q782	2SC2389S/SE/-T	SI. TRANSISTOR	
	Q783	2SA1038S/SE/-T	SILICON	
	Q784	2SA1038S/SE/-T	SILICON	
	Q802	2SC2235/OY/-T	SILICON	
	Q803	DTC123YS-T	SILICON	
△	Q821	2SB1187/EF/	SILICON	
△	Q841	2SB1187/EF/	SILICON	
△	Q851	2SD2061/EF/	SILICON	

△	Item	Parts Number	Description	Area
	Q860	DTC123YS-T	SILICON	
	Q885	2SC2240/GL/-T	SILICON	
△	Q891	2SD2061/EF/	SILICON	
	Q901	2SA1038S/SE/-T	SILICON	
	Q902	2SA1038S/SE/-T	SILICON	
	Q903	DTC123YS-T	SILICON	
	Q904	2SC1740S/RS/-T	SILICON	
	Q905	2SC2389S/SE/-T	SI. TRANSISTOR	
	Q906	2SA1038S/SE/-T	SILICON	
	Q951	DTC123YS-T	SILICON	
		CAPACITORS		
△	C001	QCZ9019-472	4700PF C. CAP.	
	C501	QETB1HM-106	10MF 50V E. CAP.	
	C502	QCS21HJ-271A	270PF 50V CER. CAP.	
	C503	QCS21HJ-101A	100PF 50V CER. CAP.	
	C504	QCB31HK-152Z	1500PF 50V CERAMIC	
	C507	QCS21HJ-220A	22PF 50V CER. CAP.	
	C508	QETB1CM-476	47MF 16V AL. E. CAP.	
	C511	QETB1HM-225	2.2MF 50V AL. E. CAP.	
	C512	QFLB1HJ-103	0.01MF 50V MYLAR CAP.	
	C513	QCS22HJ-330	33PF 500V CER. CAP.	
	C514	QETB1HM-476	47MF 50V E. CAP.	
	C517	QETB2AM-106	10MF 100V AL. E. CAP.	
	C521	QCS22HJ-470A	47PF 500V CER. CAP.	
	C522	QCS22HJ-470A	47PF 500V CER. CAP.	
	C543	QFLB1HJ-473	0.047MF 50V MYLAR CAP.	
	C544	QFLB1HJ-473	0.047MF 50V MYLAR CAP.	
	C571	QCS22HJ-470A	47PF 500V CER. CAP.	
	C572	QCS22HJ-470A	47PF 500V CER. CAP.	
	C581	QFLB1HJ-473	0.047MF 50V MYLAR CAP.	
	C582	QFLB1HJ-473	0.047MF 50V MYLAR CAP.	
	C751	QCS22HJ-470A	47PF 500V CER. CAP.	
	C752	QCS22HJ-470A	47PF 500V CER. CAP.	
	C753	QCS22HJ-470A	47PF 500V CER. CAP.	
	C754	QCS22HJ-470A	47PF 500V CER. CAP.	
	C771	QFLB1HJ-473	0.047MF 50V MYLAR CAP.	
	C772	QFLB1HJ-473	0.047MF 50V MYLAR CAP.	
	C773	QFLB1HJ-473	0.047MF 50V MYLAR CAP.	
	C774	QFLB1HJ-473	0.047MF 50V MYLAR CAP.	
	C800	QDVB1EZ-223Y	0.022MF 25V C CAP I M	
	C801	QFN82AK-472	4700PF 100V METAL. MYLAR	
	C802	QETN1EM-477Z	470MF 25V AL. E. CAP.	
	C803	QETB1CM-476	47MF 16V AL. E. CAP.	
△	C804	QCZ9019-472	4700PF C. CAP.	
	C811	QETB1VM-228N	2200MF 35V E. CAP.	
	C812	QFN82AJ-104	0.1MF 100V MYLAR CAP.	
	C813	QFN82AJ-104	0.1MF 100V MYLAR CAP.	
	C816	QCF31HZ-223Z	0.022MF 50V CERAMIC	
	C817	QCF31HZ-223Z	0.022MF 50V CERAMIC	
	C820	QCB31HK-471Y	470PF 50V CER. CAP.	
	C821	QETB1HM-476	47MF 50V E. CAP.	
	C822	QETB1HM-476	47MF 50V E. CAP.	
	C831	QETB1EM-107	100MF 25V AL. E. CAP.	
	C832	QFVJ1HJ-334Z	0.33MF 50V T. FILM	
	C833	QFLB1HJ-104	0.1MF 50V MYLAR CAP.	
	C840	QETB1HM-476	47MF 50V E. CAP.	
	C841	QETB1HM-476	47MF 50V E. CAP.	
	C845	QETB1HM-476	47MF 50V E. CAP.	
	C853	QETB1EM-107	100MF 25V AL. E. CAP.	
	C854	QETB1EM-107	100MF 25V AL. E. CAP.	
△	C861	QE20225-478	4700MF E. CAP.	
△	C862	QE20225-478	4700MF E. CAP.	
	C863	QFN82CK-104	0.1MF 160V METAL. MYLAR	
	C864	QFN82CK-104	0.1MF 160V METAL. MYLAR	
	C865	QFN82CK-104	0.1MF 160V METAL. MYLAR	
	C885	QETB1HM-105	1MF 50V AL. E. CAP.	

■ Electrical Parts List (Main P.C.B.)

△	Item	Parts Number	Description	Area
	C896	QETB1EM-107	100MF 25V AL E. CAP.	
	C897	QETB1EM-107	100MF 25V AL E. CAP.	
	C903	QETB1EM-476	47MF 16V AL E. CAP.	
	C904	QETB1EM-106	10MF 25V AL E. CAP.	
	C931	QFLB1HJ-223	0.022MF 50V MYLAR CAP.	
	C932	QFLB1HJ-223	0.022MF 50V MYLAR CAP.	
	C933	QFLB1HJ-223	0.022MF 50V MYLAR CAP.	
	C934	QFLB1HJ-223	0.022MF 50V MYLAR CAP.	
	C935	QCS21HJ-221	220PF 50V CER. CAP.	
	C936	QCS21HJ-221	220PF 50V CER. CAP.	
	C937	QCS21HJ-221	220PF 50V CER. CAP.	
	C938	QCS21HJ-221	220PF 50V CER. CAP.	
	C941	QCS21HJ-221	220PF 50V CER. CAP.	
	C942	QCS21HJ-221	220PF 50V CER. CAP.	
	C943	QCS21HJ-221	220PF 50V CER. CAP.	
	C944	QCS21HJ-221	220PF 50V CER. CAP.	
	C945	QCS21HJ-221	220PF 50V CER. CAP.	
	C946	QCS21HJ-221	220PF 50V CER. CAP.	
	C961	QCB1HK-331Y	330PF 50V CER. CAP.	
	C962	QCB1HK-331Y	330PF 50V CER. CAP.	
	C971	QFLB1HJ-223	0.022MF 50V MYLAR CAP.	
	C972	QCS21HJ-221	220PF 50V CER. CAP.	
	C973	QCS21HJ-221	220PF 50V CER. CAP.	
	C974	QCS21HJ-221	220PF 50V CER. CAP.	
	C981	QFLB1HJ-223	0.022MF 50V MYLAR CAP.	
	C982	QFLB1HJ-223	0.022MF 50V MYLAR CAP.	
	C983	QCS21HJ-221	220PF 50V CER. CAP.	
	C984	QCS21HJ-221	220PF 50V CER. CAP.	
	C985	QCS21HJ-221	220PF 50V CER. CAP.	
	C986	QCS21HJ-221	220PF 50V CER. CAP.	
	C987	QCS21HJ-221	220PF 50V CER. CAP.	
		RESISTORS		
	R501	QRE141J-222Y	2.2K 1/4W R. NETWORK	
	R502	QRE141J-563Y	56K 1/4W R. NETWORK	
	R503	QRE141J-302Y	3K 1/4W R. NETWORK	
	R504	QRE141J-101Y	100 1/4W R. NETWORK	
	R505	QRE141J-183Y	18K 1/4W R. NETWORK	
	R507	QRE141J-563Y	56K 1/4W R. NETWORK	
	R508	QRE141J-511Y	510 1/4W R. NETWORK	
△	R511	QRJ146J-331X	330 1/4W R. NETWORK	
	R512	QRE141J-302Y	3K 1/4W R. NETWORK	
	R513	QRE141J-302Y	3K 1/4W R. NETWORK	
	R514	QRE141J-302Y	3K 1/4W R. NETWORK	
	R515	QRE141J-302Y	3K 1/4W R. NETWORK	
△	R517	QRJ146J-100X	10 1/4W R. NETWORK	
△	R518	QRJ146J-100X	10 1/4W R. NETWORK	
△	R523	QRJ146J-100X	10 1/4W R. NETWORK	
△	R524	QRJ146J-100X	10 1/4W R. NETWORK	
△	R527	QRZ0195-R22	0.22 1W FUSIBLE RES.	
△	R528	QRJ129J-330	33 1/2W R. NETWORK	
	R531	QRE141J-102Y	1K 1/4W R. NETWORK	
	R532	QRE141J-183Y	18K 1/4W R. NETWORK	
	R533	QRE141J-123Y	12K 1/4W R. NETWORK	
	R541	QRE141J-471Y	470 1/4W R. NETWORK	
	R542	QRE141J-361Y	360 1/4W R. NETWORK	
	R543	QRE141J-181Y	180 1/4W R. NETWORK	
	R544	QRE141J-181Y	180 1/4W R. NETWORK	
	R545	QRE141J-181Y	180 1/4W R. NETWORK	
	R546	QRE141J-181Y	180 1/4W R. NETWORK	
△	R547	QRL022J-100	10 2W R. NETWORK	
	R548	QRE141J-104Y	100K 1/4W R. NETWORK	
	R549	QRE141J-301Y	300 1/4W R. NETWORK	
	R562	QRE141J-471Y	470 1/4W R. NETWORK	
	R567	QRE141J-361Y	360 1/4W R. NETWORK	
△	R571	QRJ146J-100X	10 1/4W R. NETWORK	
△	R572	QRJ146J-100X	10 1/4W R. NETWORK	

△	Item	Parts Number	Description	Area
	R576	QRE141J-301Y	300 1/4W R. NETWORK	
△	R577	QRZ0195-R22	0.22 1W FUSIBLE RES.	
△	R581	QRJ129J-330	33 1/2W R. NETWORK	
△	R582	QRL022J-100	10 2W R. NETWORK	
	R585	QRE141J-181Y	180 1/4W R. NETWORK	
	R586	QRE141J-181Y	180 1/4W R. NETWORK	
	R587	QRE141J-181Y	180 1/4W R. NETWORK	
	R588	QRE141J-181Y	180 1/4W R. NETWORK	
	R591	QRE141J-102Y	1K 1/4W R. NETWORK	
	R592	QRE141J-183Y	18K 1/4W R. NETWORK	
	R593	QRE141J-473Y	47K 1/4W R. NETWORK	
	R594	QRE141J-104Y	100K 1/4W R. NETWORK	
	R743	QRE141J-471Y	470 1/4W R. NETWORK	
	R744	QRE141J-471Y	470 1/4W R. NETWORK	
	R745	QRE141J-361Y	360 1/4W R. NETWORK	
	R746	QRE141J-361Y	360 1/4W R. NETWORK	
	R747	QRE141J-471Y	470 1/4W R. NETWORK	
	R748	QRE141J-471Y	470 1/4W R. NETWORK	
△	R751	QRJ146J-100X	10 1/4W R. NETWORK	
△	R752	QRJ146J-100X	10 1/4W R. NETWORK	
△	R753	QRJ146J-100X	10 1/4W R. NETWORK	
△	R754	QRJ146J-100X	10 1/4W R. NETWORK	
△	R771	QRZ0195-R22	0.22 1W FUSIBLE RES.	
△	R772	QRZ0195-R22	0.22 1W FUSIBLE RES.	
△	R773	QRJ129J-330	33 1/2W R. NETWORK	
△	R774	QRJ129J-330	33 1/2W R. NETWORK	
△	R775	QRL022J-100	10 2W R. NETWORK	
△	R776	QRL022J-100	10 2W R. NETWORK	
	R781	QRE141J-181Y	180 1/4W R. NETWORK	
	R782	QRE141J-181Y	180 1/4W R. NETWORK	
	R783	QRE141J-181Y	180 1/4W R. NETWORK	
	R784	QRE141J-181Y	180 1/4W R. NETWORK	
	R785	QRE141J-121Y	120 1/4W R. NETWORK	
	R786	QRE141J-121Y	120 1/4W R. NETWORK	
	R787	QRE141J-121Y	120 1/4W R. NETWORK	
	R788	QRE141J-121Y	120 1/4W R. NETWORK	
△	R801	QRZ9005-220X	22 FUSIBLE	
△	R803	QRJ146J-821X	820 1/4W R. NETWORK	
△	R805	QRJ146J-100X	10 1/4W R. NETWORK	
△	R808	QRJ146J-2R7X	2.7 1/4W R. NETWORK	
△	R821	QRJ146J-100X	10 1/4W R. NETWORK	
△	R822	QRJ146J-182X	1.8K 1/4W R. NETWORK	
△	R830	QRZ9006-4R7X	4.7 FUSIBLE	
△	R831	QRZ9006-4R7X	4.7 FUSIBLE	
△	R832	QRJ146J-272X	2.7K 1/4W R. NETWORK	
△	R840	QRJ146J-220X	22 1/4W R. NETWORK	
△	R841	QRZ9005-100X	10 FUSIBLE	
△	R842	QRJ146J-472X	4.7K 1/4W R. NETWORK	
△	R845	QRJ146J-102X	1K 1/4W R. NETWORK	
△	R853	QRZ9005-100X	10 FUSIBLE	
△	R854	QRK126J-562X	5.6K 1/2W R. NETWORK	
△	R860	QRJ146J-220X	22 1/4W R. NETWORK	
	R861	QRE141J-104Y	100K 1/4W R. NETWORK	
	R862	QRE141J-104Y	100K 1/4W R. NETWORK	
	R885	QRE141J-104Y	100K 1/4W R. NETWORK	
△	R891	QRZ9005-100X	10 FUSIBLE	
△	R892	QRJ146J-272X	2.7K 1/4W R. NETWORK	
	R901	QRE141J-102Y	1K 1/4W R. NETWORK	
	R902	QRE141J-102Y	1K 1/4W R. NETWORK	
	R903	QRE141J-153Y	15K 1/4W R. NETWORK	
	R904	QRE141J-153Y	15K 1/4W R. NETWORK	
	R905	QRE141J-473Y	47K 1/4W R. NETWORK	
	R906	QRE141J-473Y	47K 1/4W R. NETWORK	
	R909	QRE141J-104Y	100K 1/4W R. NETWORK	
	R910	QRE141J-823Y	82K 1/4W R. NETWORK	
	R911	QRE141J-103Y	10K 1/4W R. NETWORK	

RX554RBK

■Electrical Parts List (Main P.C.B.)

△	Item	Parts Number	Description	Area
	R915	QRE141J-103Y	10K 1/4W R. NETWORK	
	R916	QRE141J-104Y	100K 1/4W R. NETWORK	
	R917	QRE141J-103Y	10K 1/4W R. NETWORK	
	R918	QRE141J-104Y	100K 1/4W R. NETWORK	
△	R921	QRJ146J-220X	22 1/4W R. NETWORK	
△	R931	QRZ9006-4R7X	4.7 FUSIBLE	
△	R932	QRZ9006-4R7X	4.7 FUSIBLE	
△	R933	QRZ9006-4R7X	4.7 FUSIBLE	
△	R934	QRZ9006-4R7X	4.7 FUSIBLE	
△	R951	QRJ146J-220X	22 1/4W R. NETWORK	
△	R961	QRL022J-471	470 2W R. NETWORK	
△	R962	QRL022J-471	470 2W R. NETWORK	
△	R971	QRZ9006-4R7X	4.7 FUSIBLE	
△	R981	QRZ9006-4R7X	4.7 FUSIBLE	
△	R982	QRZ9006-4R7X	4.7 FUSIBLE	
	VR741	GVP0004-102Z	1K VARIABLE	
	VR742	GVP0004-102Z	1K VARIABLE	
		OTHERS		
		QWE880-38RR	VINYL WIRE	
		QWE881-16RR	VINYL WIRE	
		QWE882-38RR	VINYL WIRE	
		QWE886-16RR	PIN WIRE	
		QYSBSG3008E	T. SCREW	
	J961	QNS0023-001	JACK	
	L501	QQLZ005-R45	INDUCTOR	
	L581	QQLZ005-R45	INDUCTOR	
	L771	QQLZ005-R45	INDUCTOR	
	L772	QQLZ005-R45	INDUCTOR	
	L931	QQLZ005-R45	INDUCTOR	
	L932	QQLZ005-R45	INDUCTOR	
	L971	QQLZ005-R45	INDUCTOR	
	L981	QQLZ005-R45	INDUCTOR	
△	S001	QSW0650-001	PUSH SWITCH	
	S901	QSW0653-001	PUSH SWITCH	
△	T801	ETP1000-41EA	POWER TRANSFORMER	
	CN711	QGB2510J1-10	CONNECTOR	
	CN713	QGB2510J1-05	CONNECTOR	
	CN811	QGF1205C1-13	CONNECTOR	
	CN831	QGD2501C1-03Z	SOCKET	
	CN851	QGB2510J1-06	CONNECTOR	
	EP110	QNZ0136-001Z	1M EARTH PLATE	
	EP500	QNZ0136-001Z	1M EARTH PLATE	
	EP800	E409182-001SM	EARTH TERMINAL	
	EP901	E409182-001SM	EARTH TERMINAL	
	EP961	QNZ0136-001Z	1M EARTH PLATE	
	FC801	QNG0020-001Z	FUSE CLIP I.M	
	FC802	QNG0020-001Z	FUSE CLIP I.M	
	FC803	QNG0020-001Z	FUSE CLIP I.M	
	FC804	QNG0020-001Z	FUSE CLIP I.M	
	FC810	QNG0020-001Z	FUSE CLIP I.M	
	FC811	QNG0020-001Z	FUSE CLIP I.M	
	FC812	QNG0020-001Z	FUSE CLIP I.M	
	FC813	QNG0020-001Z	FUSE CLIP I.M	
	FW801	EWR3AD-13SS	FLAT WIRE	
	FW831	EWR33D-10LS	FLAT WIRE	
	FW901	EWR36D-40SS	CORD	
	FW902	EWR35B-16SS1	FLAT WIRE	
	FW961	EWR33D-10SS	CORD	
	HS841	E70306-001	HEAT SINK	
	HS851	E70946-H40B	HEAT SINK	
	HS891	E70306-001	HEAT SINK	
△	LA101	E67132-T2R0	FUSE LABEL	
△	LA811	E67132-T2R0	FUSE LABEL	
△	LA812	E67132-T2R0	FUSE LABEL	
△	RY801	QSK0055-001	RELAY	
	RY860	QSK0082-001	RELAY	

△	Item	Parts Number	Description	Area
	RY921	QSK0057-001	RELAY	
	RY961	QSK0057-001	RELAY	
	ST901	QNB0007-001	SPK TERMINAL	
	ST951	QNB0016-001	SPK TERMINAL	
	TA801	QNZ0079-001Z	TAB I.M	
	TA802	QNZ0079-001Z	TAB I.M	
	TH540	QAD0012-202	THERMISTOR	
	TH568	QAD0012-202	THERMISTOR	
	TH749	QAD0012-202	THERMISTOR	
	TH750	QAD0012-202	THERMISTOR	
	TP001	QMV5005-004K	PLUG ASSY	

■Electrical Parts List (Control P.C.B.)

△	Item	Parts Number	Description	Area
		I. C. S		
	IC251	MS243AP12	I. C (M)	
	IC252	TC9163AN	I. C (DIGI-MOS)	
	IC301	NJM4580D-D	I. C.	
	IC311	NJM4580L	I. C (MONO-ANALOG)	
	IC312	NJM4580L	I. C (MONO-ANALOG)	
	IC313	NJM4580L	I. C (MONO-ANALOG)	
	IC321	TC9164AM	I. C (DIGI-MOS)	
	IC323	UPD4066BC	I. C (DIGI-MOS)	
	IC332	BA15218	I. C (MONO-ANALOG)	
	IC341	TC9412AP	I. C (M)	
	IC343	TC9413AP	I. C (M)	
		DIODES		
	D251	MTZJ6. 8C-T2	ZENER	
	D252	MTZJ6. 8C-T2	ZENER	
	D301	MTZJ8. 2C-T2	ZENER	
	D302	MTZJ8. 2C-T2	ZENER	
		TRANSISTORS		
	Q351	DTA144ES-T	SILICON	
	Q352	DTC144ES-T	SILICON	
	Q353	DTA144ES-T	SILICON	
	Q401	2SD2144S/VW/-T	SILICON	
	Q402	2SD2144S/VW/-T	SILICON	
	Q405	2SD2144S/VW/-T	SILICON	
	Q406	2SD2144S/VW/-T	SILICON	
	Q408	DTA144ES-T	SILICON	
		CAPACITORS		
	C231	QCBB1HK-221Y	220PF 50V CER. CAP.	
	C253	QCBB1HK-101Y	100PF 50V CER. CAP.	
	C254	QCBB1HK-101Y	100PF 50V CER. CAP.	
	C255	QETB1EM-476	47MF 25V AL. E. CAP.	
	C256	QETB1EM-476	47MF 25V AL. E. CAP.	
	C257	QETB1EM-476	47MF 25V AL. E. CAP.	
	C258	QETB1EM-476	47MF 25V AL. E. CAP.	
	C259	QCSB1HJ-100Y	10PF 50V CER. CAP.	
	C260	QCSB1HJ-100Y	10PF 50V CER. CAP.	
	C261	QCSB1HJ-100Y	10PF 50V CER. CAP.	
	C262	QCSB1HJ-100Y	10PF 50V CER. CAP.	
	C265	QETB1EM-226N	22MF 25V E. CAP.	
	C266	QETB1EM-226N	22MF 25V E. CAP.	
	C269	QDVB1EZ-223Y	0. 022MF 25V C CAP I M	
	C270	QDVB1EZ-223Y	0. 022MF 25V C CAP I M	
	C271	QFLB1HJ-272	2700PF 50V NYLAR CAP.	
	C272	QFLB1HJ-272	2700PF 50V NYLAR CAP.	
	C273	QCBB1HK-471Y	470PF 50V CER. CAP.	
	C274	QCBB1HK-471Y	470PF 50V CER. CAP.	
	C275	QFVJ1HJ-473Z	0. 047MF 50V T. FILM	
	C276	QFVJ1HJ-473Z	0. 047MF 50V T. FILM	
	C277	QFLB1HJ-822	8200PF 50V NYLAR CAP.	
	C278	QFLB1HJ-822	8200PF 50V NYLAR CAP.	
	C279	QFVJ1HJ-684Z	0. 68MF 50V T. FILM	
	C280	QFVJ1HJ-684Z	0. 68MF 50V T. FILM	
	C281	QFVJ1HJ-104Z	0. 1MF 50V T. FILM	
	C282	QFVJ1HJ-104Z	0. 1MF 50V T. FILM	
	C283	QCSB1HJ-470	47PF 50V CER. CAP.	
	C284	QCSB1HJ-470	47PF 50V CER. CAP.	
	C287	QCBB1HK-561Y	560PF 50V CER. CAP.	
	C300	QDVB1EZ-223Y	0. 022MF 25V C CAP I M	
	C301	QETB1HM-475E	4. 7MF 50V E. CAP.	
	C302	QETB1HM-475E	4. 7MF 50V E. CAP.	
	C303	QCBB1HK-101Y	100PF 50V CER. CAP.	
	C304	QCBB1HK-101Y	100PF 50V CER. CAP.	
	C305	QFLB1HJ-182	1800PF 50V NYLAR CAP.	
	C306	QFLB1HJ-182	1800PF 50V NYLAR CAP.	
	C307	QFLB1HJ-682	6800PF 50V NYLAR CAP.	
	C308	QFLB1HJ-682	6800PF 50V NYLAR CAP.	
	C309	QCS21HJ-101A	100PF 50V CER. CAP.	
	C310	QCS21HJ-101A	100PF 50V CER. CAP.	
	C311	QETB1HM-475E	4. 7MF 50V E. CAP.	

△	Item	Parts Number	Description	Area
	C312	QETB1HM-475E	4. 7MF 50V E. CAP.	
	C313	QETC1AM-107ZN	100MF 10V E. CAP.	
	C314	QETC1AM-107ZN	100MF 10V E. CAP.	
	C315	QETB1CM-476	47MF 16V AL. E. CAP.	
	C316	QETB1CM-476	47MF 16V AL. E. CAP.	
	C321	QDVB1EZ-223Y	0. 022MF 25V C CAP I M	
	C322	QDVB1EZ-223Y	0. 022MF 25V C CAP I M	
	C323	QCBB1HK-221Y	220PF 50V CER. CAP.	
	C325	QCBB1HK-331Y	330PF 50V CER. CAP.	
	C326	QCBB1HK-331Y	330PF 50V CER. CAP.	
	C327	QCBB1HK-331Y	330PF 50V CER. CAP.	
	C328	QCBB1HK-331Y	330PF 50V CER. CAP.	
	C329	QCBB1HK-331Y	330PF 50V CER. CAP.	
	C330	QCBB1HK-331Y	330PF 50V CER. CAP.	
	C331	QCBB1HK-331Y	330PF 50V CER. CAP.	
	C332	QCBB1HK-331Y	330PF 50V CER. CAP.	
	C333	QCBB1HK-331Y	330PF 50V CER. CAP.	
	C334	QCBB1HK-331Y	330PF 50V CER. CAP.	
	C335	QCBB1HK-331Y	330PF 50V CER. CAP.	
	C336	QCBB1HK-331Y	330PF 50V CER. CAP.	
	C337	QCBB1HK-331Y	330PF 50V CER. CAP.	
	C338	QCBB1HK-331Y	330PF 50V CER. CAP.	
	C339	QCBB1HK-221Y	220PF 50V CER. CAP.	
	C340	QCBB1HK-221Y	220PF 50V CER. CAP.	
	C341	QETB1HM-475E	4. 7MF 50V E. CAP.	
	C342	QETB1HM-475E	4. 7MF 50V E. CAP.	
	C343	QETB1HM-475E	4. 7MF 50V E. CAP.	
	C344	QETB1HM-475E	4. 7MF 50V E. CAP.	
	C345	QDVB1EZ-223Y	0. 022MF 25V C CAP I M	
	C346	QDVB1EZ-223Y	0. 022MF 25V C CAP I M	
	C347	QCBB1HK-221Y	220PF 50V CER. CAP.	
	C348	QCBB1HK-221Y	220PF 50V CER. CAP.	
	C351	QETB1HM-105	1MF 50V AL. E. CAP.	
	C352	QETB1HM-105	1MF 50V AL. E. CAP.	
	C353	QDVB1EZ-223Y	0. 022MF 25V C CAP I M	
	C354	QDVB1EZ-223Y	0. 022MF 25V C CAP I M	
	C355	QETB1HM-105	1MF 50V AL. E. CAP.	
	C356	QETB1HM-105	1MF 50V AL. E. CAP.	
	C357	QDVB1EZ-223Y	0. 022MF 25V C CAP I M	
	C358	QDVB1EZ-223Y	0. 022MF 25V C CAP I M	
	C359	QDVB1EZ-223Y	0. 022MF 25V C CAP I M	
	C360	QDVB1EZ-223Y	0. 022MF 25V C CAP I M	
	C361	QETB1HM-475E	4. 7MF 50V E. CAP.	
	C362	QETB1EM-226N	22MF 25V E. CAP.	
	C363	QETB1EM-226N	22MF 25V E. CAP.	
	C365	QETB1HM-475E	4. 7MF 50V E. CAP.	
	C366	QETB1HM-475E	4. 7MF 50V E. CAP.	
	C401	QDVB1EZ-223Y	0. 022MF 25V C CAP I M	
	C402	QDVB1EZ-223Y	0. 022MF 25V C CAP I M	
	C403	QETB1HM-225	2. 2MF 50V AL. E. CAP.	
	C404	QETB1HM-225	2. 2MF 50V AL. E. CAP.	
	C405	QCBB1HK-561Y	560PF 50V CER. CAP.	
	C406	QCBB1HK-561Y	560PF 50V CER. CAP.	
	C407	QFVJ1HJ-274Z	0. 27MF 50V T. FILM	
	C408	QFVJ1HJ-274Z	0. 27MF 50V T. FILM	
	C409	QETB1HM-475E	4. 7MF 50V E. CAP.	
	C410	QETB1HM-475E	4. 7MF 50V E. CAP.	
	C421	QDVB1EZ-223Y	0. 022MF 25V C CAP I M	
	C422	QDVB1EZ-223Y	0. 022MF 25V C CAP I M	
	C423	QETB1HM-475E	4. 7MF 50V E. CAP.	
	C424	QETB1HM-475E	4. 7MF 50V E. CAP.	
	C425	QETB1HM-475E	4. 7MF 50V E. CAP.	
	C426	QETB1HM-475E	4. 7MF 50V E. CAP.	
	C427	QETB1HM-475E	4. 7MF 50V E. CAP.	
	C428	QETB1HM-475E	4. 7MF 50V E. CAP.	
	C431	QETC1AM-107ZN	100MF 10V E. CAP.	
		RESISTORS		
	R231	QRE141J-471Y	470 1/4W R. NETWORK	
	R232	QRE141J-221Y	220 1/4W R. NETWORK	

RX554RBK

■Electrical Parts List (Control P.C.B.)

△	Item	Parts Number	Description	Area
	R255	QRE141J-393Y	39K 1/4W R. NETWORK	
	R256	QRE141J-393Y	39K 1/4W R. NETWORK	
	R257	QRE141J-103Y	10K 1/4W R. NETWORK	
	R258	QRE141J-103Y	10K 1/4W R. NETWORK	
	R259	QRE141J-103Y	10K 1/4W R. NETWORK	
	R260	QRE141J-103Y	10K 1/4W R. NETWORK	
	R261	QRE141J-303Y	30K 1/4W R. NETWORK	
	R262	QRE141J-303Y	30K 1/4W R. NETWORK	
	R263	QRE141J-123Y	12K 1/4W R. NETWORK	
	R264	QRE141J-123Y	12K 1/4W R. NETWORK	
	R265	QRE141J-472Y	4. 7K 1/4W R. NETWORK	
	R266	QRE141J-472Y	4. 7K 1/4W R. NETWORK	
	R267	QRE141J-183Y	18K 1/4W R. NETWORK	
	R268	QRE141J-183Y	18K 1/4W R. NETWORK	
	R269	QRE141J-912Y	9. 1K 1/4W R. NETWORK	
	R270	QRE141J-912Y	9. 1K 1/4W R. NETWORK	
	R271	QRE141J-243Y	24K 1/4W R. NETWORK	
	R272	QRE141J-243Y	24K 1/4W R. NETWORK	
	R273	QRE141J-103Y	10K 1/4W R. NETWORK	
	R274	QRE141J-103Y	10K 1/4W R. NETWORK	
	R275	QRE141J-333Y	33K 1/4W R. NETWORK	
	R276	QRE141J-333Y	33K 1/4W R. NETWORK	
	R279	QRE141J-681Y	680 1/4W R. NETWORK	
	R280	QRE141J-681Y	680 1/4W R. NETWORK	
	R301	QRE141J-222Y	2. 2K 1/4W R. NETWORK	
	R302	QRE141J-222Y	2. 2K 1/4W R. NETWORK	
	R303	QRE141J-473Y	47K 1/4W R. NETWORK	
	R304	QRE141J-473Y	47K 1/4W R. NETWORK	
	R305	QRE141J-561Y	560 1/4W R. NETWORK	
	R306	QRE141J-561Y	560 1/4W R. NETWORK	
	R307	QRE141J-393Y	39K 1/4W R. NETWORK	
	R308	QRE141J-393Y	39K 1/4W R. NETWORK	
	R309	QRE141J-474Y	470K 1/4W R. NETWORK	
	R310	QRE141J-474Y	470K 1/4W R. NETWORK	
	R311	QRE141J-104Y	100K 1/4W R. NETWORK	
	R312	QRE141J-104Y	100K 1/4W R. NETWORK	
△	R313	QRJ146J-391X	390 1/4W R. NETWORK	
△	R314	QRJ146J-391X	390 1/4W R. NETWORK	
	R321	QRE141J-271Y	270 1/4W R. NETWORK	
	R322	QRE141J-271Y	270 1/4W R. NETWORK	
	R323	QRE141J-102Y	1K 1/4W R. NETWORK	
	R325	QRE141J-471Y	470 1/4W R. NETWORK	
	R326	QRE141J-471Y	470 1/4W R. NETWORK	
	R327	QRE141J-471Y	470 1/4W R. NETWORK	
	R328	QRE141J-471Y	470 1/4W R. NETWORK	
	R329	QRE141J-471Y	470 1/4W R. NETWORK	
	R330	QRE141J-471Y	470 1/4W R. NETWORK	
	R331	QRE141J-471Y	470 1/4W R. NETWORK	
	R332	QRE141J-471Y	470 1/4W R. NETWORK	
	R333	QRE141J-471Y	470 1/4W R. NETWORK	
	R334	QRE141J-471Y	470 1/4W R. NETWORK	
	R335	QRE141J-471Y	470 1/4W R. NETWORK	
	R336	QRE141J-471Y	470 1/4W R. NETWORK	
	R341	QRE141J-104Y	100K 1/4W R. NETWORK	
	R342	QRE141J-104Y	100K 1/4W R. NETWORK	
	R343	QRE141J-104Y	100K 1/4W R. NETWORK	
	R344	QRE141J-104Y	100K 1/4W R. NETWORK	
△	R345	QRJ146J-271X	270 1/4W R. NETWORK	
△	R346	QRJ146J-271X	270 1/4W R. NETWORK	
	R347	QRE141J-153Y	15K 1/4W R. NETWORK	
	R348	QRE141J-153Y	15K 1/4W R. NETWORK	
	R349	QRE141J-153Y	15K 1/4W R. NETWORK	
	R350	QRE141J-153Y	15K 1/4W R. NETWORK	
	R351	QRE141J-303Y	30K 1/4W R. NETWORK	
	R352	QRE141J-303Y	30K 1/4W R. NETWORK	
	R353	QRE141J-103Y	10K 1/4W R. NETWORK	
	R354	QRE141J-103Y	10K 1/4W R. NETWORK	
	R355	QRE141J-104Y	100K 1/4W R. NETWORK	
	R356	QRE141J-104Y	100K 1/4W R. NETWORK	

△	Item	Parts Number	Description	Area
△	R361	QRJ146J-271X	270 1/4W R. NETWORK	
△	R362	QRJ146J-271X	270 1/4W R. NETWORK	
	R363	QRE141J-912Y	9. 1K 1/4W R. NETWORK	
	R364	QRE141J-912Y	9. 1K 1/4W R. NETWORK	
	R365	QRE141J-102Y	1K 1/4W R. NETWORK	
	R366	QRE141J-102Y	1K 1/4W R. NETWORK	
	R367	QRE141J-104Y	100K 1/4W R. NETWORK	
	R368	QRE141J-104Y	100K 1/4W R. NETWORK	
	R371	QRE141J-821Y	820 1/4W R. NETWORK	
	R372	QRE141J-821Y	820 1/4W R. NETWORK	
	R373	QRE141J-102Y	1K 1/4W R. NETWORK	
	R374	QRE141J-103Y	10K 1/4W R. NETWORK	
	R375	QRE141J-103Y	10K 1/4W R. NETWORK	
	R377	QRE141J-104Y	100K 1/4W R. NETWORK	
	R378	QRE141J-104Y	100K 1/4W R. NETWORK	
△	R401	QRZ9005-680X	68 FUSIBLE	
△	R402	QRZ9005-680X	68 FUSIBLE	
	R403	QRE141J-393Y	39K 1/4W R. NETWORK	
	R404	QRE141J-393Y	39K 1/4W R. NETWORK	
	R405	QRE141J-224Y	220K 1/4W R. NETWORK	
	R406	QRE141J-224Y	220K 1/4W R. NETWORK	
	R407	QRE141J-154Y	150K 1/4W R. NETWORK	
	R408	QRE141J-154Y	150K 1/4W R. NETWORK	
	R409	QRE141J-103Y	10K 1/4W R. NETWORK	
	R410	QRE141J-103Y	10K 1/4W R. NETWORK	
	R429	QRE141J-104Y	100K 1/4W R. NETWORK	
	R430	QRE141J-104Y	100K 1/4W R. NETWORK	
	R431	QRE141J-104Y	100K 1/4W R. NETWORK	
	R432	QRE141J-104Y	100K 1/4W R. NETWORK	
	R433	QRE141J-103Y	10K 1/4W R. NETWORK	
	R434	QRE141J-103Y	10K 1/4W R. NETWORK	
	R435	QRE141J-102Y	1K 1/4W R. NETWORK	
	R436	QRE141J-102Y	1K 1/4W R. NETWORK	
	R439	QRE141J-102Y	1K 1/4W R. NETWORK	
	R440	QRE141J-102Y	1K 1/4W R. NETWORK	
	R441	QRE141J-102Y	1K 1/4W R. NETWORK	
△	R443	QRZ9005-680X	68 FUSIBLE	
△	R444	QRZ9005-680X	68 FUSIBLE	
	R445	QRE141J-154Y	150K 1/4W R. NETWORK	
	R446	QRE141J-154Y	150K 1/4W R. NETWORK	
		OTHERS		
		VWE370-094K4K	VINYL WIRE	
	CN101	QGB2510J1-12	CONNECTOR	
	CN301	QGB2510K1-12	CONNECTOR	
	CN304	QGF1205C1-27	CONNECTOR	
	CN603	QGB2510K1-12	CONNECTOR	
	CN604	QGB2510K1-10	CONNECTOR	
	CN605	QGB2510K1-06	CONNECTOR	
	CN606	QGB2510K1-04	CONNECTOR	
	CN611	QGB2510J1-08	CONNECTOR	
	CN612	QGB2510J1-09	CONNECTOR	
	CN613	QGB2510J1-12	CONNECTOR	
	CN614	QGB2510J1-10	CONNECTOR	
	CN615	QGB2510J1-06	CONNECTOR	
	CN616	QGB2510J1-04	CONNECTOR	
	CN702	EWS296-0130J	CONNECTOR WIRE ASSY	
	CN841	QGB2510K1-06	CONNECTOR	

■ Electrical Parts List (Front P.C.B.)

△	Item	Parts Number	Description	Area
		I. C. S		
	IC401	NN173222JABN1	I. C(M)	
	IC402	GP1U271X	INFRARED DETECT UNIT	
	IC403	IC-PST600/E/-T	I. C.	
	IC404	BU2092	I. C(M)	
	IC801	TC9471F	I. C(M)	
		DIODES		
	D401	1SR139-200-T4	SILICON	
	D402	1SS133-T2	SI. DIODE	
	D403	1SS133-T2	SI. DIODE	
	D404	1SS133-T2	SI. DIODE	
	D410	1SS133-T2	SI. DIODE	
	D411	SLR-342VC-T	L. E. D.	
	D418	SLR-342MC-T	L. E. D.	
	D419	SLR-342MC-T	L. E. D.	
	D420	SLR-342MC-T	L. E. D.	
	D421	SLR-342MC-T	L. E. D.	
	D422	SLR-342MC-T	L. E. D.	
	D423	SLR-342MC-T	L. E. D.	
	D424	SLR-342MC-T	L. E. D.	
	D431	1SS133-T2	SI. DIODE	
	D432	1SS133-T2	SI. DIODE	
	D433	1SS133-T2	SI. DIODE	
	D434	1SS133-T2	SI. DIODE	
	D436	1SS133-T2	SI. DIODE	
	D438	1SS133-T2	SI. DIODE	
	D441	1SS133-T2	SI. DIODE	
	D443	1SS133-T2	SI. DIODE	
	D553	1SS133-T2	SI. DIODE	
	D703	1SS133-T2	SI. DIODE	
	D704	1SS133-T2	SI. DIODE	
	D711	SLR-342MC-T	L. E. D.	
	D712	SLR-342MC-T	L. E. D.	
		TRANSISTORS		
	Q401	DTC114YS-T	SILICON	
	Q402	DTC114TSTP	DIGITAL TRANSISTOR	
	Q403	DTC114WS-T	SILICON	
	Q410	DTC114YS-T	SILICON	
	Q411	DTC114YS-T	SILICON	
	Q412	DTC114YS-T	SILICON	
	Q413	DTC114YS-T	SILICON	
	Q414	DTC114YS-T	SILICON	
	Q551	2SC2240/L/-T	SILICON	
	Q552	2SC2240/L/-T	SILICON	
	Q561	2SA1038S/SE/-T	SILICON	
	Q701	2SC2240/L/-T	SILICON	
	Q702	2SC2240/L/-T	SILICON	
	Q703	2SC2240/L/-T	SILICON	
	Q704	2SC2240/L/-T	SILICON	
	Q707	2SA1038S/SE/-T	SILICON	
	Q708	2SA1038S/SE/-T	SILICON	
	Q711	2SC2389S/SE/-T	SI. TRANSISTOR	
	Q712	2SC2389S/SE/-T	SI. TRANSISTOR	
		CAPACITORS		
	C401	QETB1AM-227	220MF 10V E. CAP.	
	C402	QCZ0202-155	1.5MF 25V CER. RES.	
	C403	QEZO329-10AZ	ELECTRO	
	C404	QETB1HM-225	2.2MF 50V AL. E. CAP.	
	C405	QDVB1EZ-223Y	0.022MF 25V C CAP I M	
	C406	QCB1HK-331Y	330PF 50V CER. CAP.	
	C411	QETB1HM-475E	4.7MF 50V E. CAP.	
	C412	QETB1HM-475E	4.7MF 50V E. CAP.	
	C413	QETC1AM-107ZN	100MF 10V E. CAP.	
	C414	QETB1HM-475E	4.7MF 50V E. CAP.	
	C551	QETB1HM-106	10MF 50V E. CAP.	
	C552	QCS21HJ-271A	270PF 50V CER. CAP.	
	C553	QCS21HJ-101A	100PF 50V CER. CAP.	
	C556	QCB31HK-152Z	1500PF 50V CERAMIC	
	C557	QCS21HJ-220A	22PF 50V CER. CAP.	

△	Item	Parts Number	Description	Area
	C558	QETB1CM-476	47MF 16V AL. E. CAP.	
	C561	QETB1HM-225	2.2MF 50V AL. E. CAP.	
	C562	QCS22HJ-330	33PF 500V CER. CAP.	
	C563	QFLB1HJ-103	0.01MF 50V MYLAR CAP.	
	C564	QETB1HM-476	47MF 50V E. CAP.	
	C601	QETB1HM-475E	4.7MF 50V E. CAP.	
	C602	QETB1HM-475E	4.7MF 50V E. CAP.	
	C603	QDXB1CM-222Y	2200PF 16V C CAP.	
	C604	QDXB1CM-222Y	2200PF 16V C CAP.	
	C605	QETB1HM-475E	4.7MF 50V E. CAP.	
	C606	QETB1HM-475E	4.7MF 50V E. CAP.	
	C607	QDXB1CM-222Y	2200PF 16V C CAP.	
	C608	QDXB1CM-222Y	2200PF 16V C CAP.	
	C609	QETB1HM-475E	4.7MF 50V E. CAP.	
	C610	QETB1HM-475E	4.7MF 50V E. CAP.	
	C611	QDXB1CM-222Y	2200PF 16V C CAP.	
	C612	QDXB1CM-222Y	2200PF 16V C CAP.	
	C613	QETC1AM-476ZM	47MF 10V E. CAP.	
	C614	QETC1AM-476ZM	47MF 10V E. CAP.	
	C615	QETC1AM-476ZM	47MF 10V E. CAP.	
	C616	QETC1AM-476ZM	47MF 10V E. CAP.	
	C617	QETC1AM-476ZM	47MF 10V E. CAP.	
	C618	QETC1AM-476ZM	47MF 10V E. CAP.	
	C619	QETC1AM-476ZM	47MF 10V E. CAP.	
	C620	QETC1AM-476ZM	47MF 10V E. CAP.	
	C621	QETC1AM-476ZM	47MF 10V E. CAP.	
	C622	QDYB1CM-103Y	0.01MF 16V C CAP.	
	C623	QETC1AM-476ZM	47MF 10V E. CAP.	
	C624	QDYB1CM-103Y	0.01MF 16V C CAP.	
	C628	QETC1AM-476ZM	47MF 10V E. CAP.	
	C630	QDYB1CM-103Y	0.01MF 16V C CAP.	
	C631	QDYB1CM-103Y	0.01MF 16V C CAP.	
	C632	QETC1AM-476ZM	47MF 10V E. CAP.	
	C633	QDYB1CM-103Y	0.01MF 16V C CAP.	
	C634	QDYB1CM-103Y	0.01MF 16V C CAP.	
	C635	QCSB1HK-102	1000PF 50V CER. CAP.	
	C636	QCSB1HJ-100Y	10PF 50V CER. CAP.	
	C637	QCSB1HJ-470	47PF 50V CER. CAP.	
	C701	QETB1HM-106	10MF 50V E. CAP.	
	C702	QETB1HM-106	10MF 50V E. CAP.	
	C703	QCS21HJ-271A	270PF 50V CER. CAP.	
	C704	QCS21HJ-271A	270PF 50V CER. CAP.	
	C705	QCS21HJ-101A	100PF 50V CER. CAP.	
	C706	QCS21HJ-101A	100PF 50V CER. CAP.	
	C711	QETB1CM-107	100MF 16V AL. E. CAP.	
	C712	QETB1CM-107	100MF 16V AL. E. CAP.	
	C713	QCS21HJ-220A	22PF 50V CER. CAP.	
	C714	QCS21HJ-220A	22PF 50V CER. CAP.	
	C717	QCB31HK-152Z	1500PF 50V CERAMIC	
	C718	QCB31HK-152Z	1500PF 50V CERAMIC	
	C721	QCS22HJ-220	22PF 500V CER. CAP.	
	C722	QCS22HJ-220	22PF 500V CER. CAP.	
	C723	QETB1HM-225	2.2MF 50V AL. E. CAP.	
	C724	QETB1HM-225	2.2MF 50V AL. E. CAP.	
	C727	QFLB1HJ-103	0.01MF 50V MYLAR CAP.	
	C728	QFLB1HJ-103	0.01MF 50V MYLAR CAP.	
	C739	QETB1JM-107	100MF 63V AL. E. CAP.	
		RESISTORS		
	R401	QRE141J-103Y	10K 1/4W R. NETWORK	
	R402	QRE141J-331Y	330 1/4W R. NETWORK	
	R403	QRE141J-223Y	22K 1/4W R. NETWORK	
	R404	QRE141J-103Y	10K 1/4W R. NETWORK	
	R405	QRE141J-472Y	4.7K 1/4W R. NETWORK	
	R408	QRE141J-103Y	10K 1/4W R. NETWORK	
	R409	QRE141J-471Y	470 1/4W R. NETWORK	
	R410	QRE141J-103Y	10K 1/4W R. NETWORK	
	R411	QRE141J-221Y	220 1/4W R. NETWORK	
	R412	QRE141J-103Y	10K 1/4W R. NETWORK	
	R413	QRE141J-103Y	10K 1/4W R. NETWORK	

RX554RBK

■Electrical Parts List (Front P.C.B.)

△	Item	Parts Number	Description	Area
	R414	QRE141J-103Y	10K 1/4W R.NETWORK	
	R417	QRE141J-221Y	220 1/4W R.NETWORK	
	R418	QRE141J-221Y	220 1/4W R.NETWORK	
	R419	QRE141J-472Y	4.7K 1/4W R.NETWORK	
	R420	QRE141J-104Y	100K 1/4W R.NETWORK	
	R421	QRE141J-104Y	100K 1/4W R.NETWORK	
	R422	QRE141J-104Y	100K 1/4W R.NETWORK	
	R423	QRE141J-222Y	2.2K 1/4W R.NETWORK	
	R424	QRE141J-222Y	2.2K 1/4W R.NETWORK	
	R425	QRE141J-222Y	2.2K 1/4W R.NETWORK	
	R426	QRE141J-222Y	2.2K 1/4W R.NETWORK	
	R433	QRE141J-104Y	100K 1/4W R.NETWORK	
	R434	QRE141J-104Y	100K 1/4W R.NETWORK	
	R435	QRE141J-104Y	100K 1/4W R.NETWORK	
	R436	QRE141J-221Y	220 1/4W R.NETWORK	
	R437	QRE141J-221Y	220 1/4W R.NETWORK	
	R438	QRE141J-221Y	220 1/4W R.NETWORK	
	R439	QRE141J-221Y	220 1/4W R.NETWORK	
	R440	QRE141J-221Y	220 1/4W R.NETWORK	
	R441	QRE141J-221Y	220 1/4W R.NETWORK	
	R442	QRE141J-221Y	220 1/4W R.NETWORK	
	R443	QRE141J-221Y	220 1/4W R.NETWORK	
	R444	QRE141J-221Y	220 1/4W R.NETWORK	
	R445	QRE141J-221Y	220 1/4W R.NETWORK	
	R446	QRE141J-221Y	220 1/4W R.NETWORK	
	R447	QRE141J-221Y	220 1/4W R.NETWORK	
	R448	QRE141J-221Y	220 1/4W R.NETWORK	
	R449	QRE141J-221Y	220 1/4W R.NETWORK	
	R450	QRE141J-221Y	220 1/4W R.NETWORK	
	R451	QRE141J-221Y	220 1/4W R.NETWORK	
	R452	QRE141J-221Y	220 1/4W R.NETWORK	
	R453	QRE141J-221Y	220 1/4W R.NETWORK	
	R454	QRE141J-221Y	220 1/4W R.NETWORK	
	R455	QRE141J-221Y	220 1/4W R.NETWORK	
	R456	QRE141J-221Y	220 1/4W R.NETWORK	
	R457	QRE141J-221Y	220 1/4W R.NETWORK	
	R458	QRE141J-221Y	220 1/4W R.NETWORK	
	R459	QRE141J-221Y	220 1/4W R.NETWORK	
	R551	QRE141J-222Y	2.2K 1/4W R.NETWORK	
	R552	QRE141J-563Y	56K 1/4W R.NETWORK	
	R553	QRE141J-302Y	3K 1/4W R.NETWORK	
	R555	QRE141J-183Y	18K 1/4W R.NETWORK	
	R556	QRE141J-101Y	100 1/4W R.NETWORK	
	R558	QRE141J-511Y	510 1/4W R.NETWORK	
	R560	QRE141J-563Y	56K 1/4W R.NETWORK	
△	R561	QRJ146J-331X	330 1/4W R.NETWORK	
	R563	QRE141J-302Y	3K 1/4W R.NETWORK	
	R564	QRE141J-302Y	3K 1/4W R.NETWORK	
	R565	QRE141J-302Y	3K 1/4W R.NETWORK	
	R566	QRE141J-302Y	3K 1/4W R.NETWORK	
△	R569	QRJ146J-100X	10 1/4W R.NETWORK	
△	R570	QRJ146J-100X	10 1/4W R.NETWORK	
	R601	QRE141J-271Y	270 1/4W R.NETWORK	
	R602	QRE141J-271Y	270 1/4W R.NETWORK	
	R603	QRE141J-271Y	270 1/4W R.NETWORK	
	R604	QRE141J-271Y	270 1/4W R.NETWORK	
	R605	QRE141J-271Y	270 1/4W R.NETWORK	
	R606	QRE141J-271Y	270 1/4W R.NETWORK	
	R607	QRE141J-225Y	2.2M 1/4W R.NETWORK	
	R608	QRE141J-104Y	100K 1/4W R.NETWORK	
	R609	QRE141J-104Y	100K 1/4W R.NETWORK	
	R610	QRE141J-104Y	100K 1/4W R.NETWORK	
	R611	QRE141J-104Y	100K 1/4W R.NETWORK	
	R612	QRE141J-103Y	10K 1/4W R.NETWORK	
	R613	QRE141J-103Y	10K 1/4W R.NETWORK	
	R614	QRE141J-103Y	10K 1/4W R.NETWORK	
	R701	QRE141J-222Y	2.2K 1/4W R.NETWORK	
	R702	QRE141J-222Y	2.2K 1/4W R.NETWORK	
	R703	QRE141J-563Y	56K 1/4W R.NETWORK	

△	Item	Parts Number	Description	Area
	R704	QRE141J-563Y	56K 1/4W R.NETWORK	
	R705	QRE141J-332Y	3.3K 1/4W R.NETWORK	
	R706	QRE141J-332Y	3.3K 1/4W R.NETWORK	
	R709	QRE141J-183Y	18K 1/4W R.NETWORK	
	R710	QRE141J-183Y	18K 1/4W R.NETWORK	
	R711	QRE141J-511Y	510 1/4W R.NETWORK	
	R712	QRE141J-511Y	510 1/4W R.NETWORK	
	R713	QRE141J-563Y	56K 1/4W R.NETWORK	
	R714	QRE141J-563Y	56K 1/4W R.NETWORK	
	R717	QRE141J-101Y	100 1/4W R.NETWORK	
	R718	QRE141J-101Y	100 1/4W R.NETWORK	
△	R721	QRJ146J-331X	330 1/4W R.NETWORK	
△	R722	QRJ146J-331X	330 1/4W R.NETWORK	
	R727	QRE141J-473Y	47K 1/4W R.NETWORK	
	R728	QRE141J-473Y	47K 1/4W R.NETWORK	
△	R729	QRJ146J-331X	330 1/4W R.NETWORK	
△	R730	QRJ146J-331X	330 1/4W R.NETWORK	
△	R739	QRJ146J-100X	10 1/4W R.NETWORK	
△	R740	QRJ146J-100X	10 1/4W R.NETWORK	
	RA401	QRB049J-103	10K 1/10WRES.	
	RA402	QRB109J-103	10K 1/10WNETWORK RES.	
		OTHERS		
		E3400-431	FELT SPACER	
		VWE350-144K4K	VINYL WIRE	
		VWE370-04A1A1	VINYL WIRE	
		VWE370-08A1A1	VINYL WIRE	
	L601	QQL121M-2R2Y	INDUCTOR I.M	
	S401	QSW0683-001Z	PUSH SWITCH	
	S402	QSW0683-001Z	PUSH SWITCH	
	S403	QSW0683-001Z	PUSH SWITCH	
	S404	QSW0683-001Z	PUSH SWITCH	
	S405	QSW0683-001Z	PUSH SWITCH	
	S406	QSW0683-001Z	PUSH SWITCH	
	S407	QSW0683-001Z	PUSH SWITCH	
	S408	QSW0683-001Z	PUSH SWITCH	
	S409	QSW0683-001Z	PUSH SWITCH	
	S410	QSW0683-001Z	PUSH SWITCH	
	S411	QSW0683-001Z	PUSH SWITCH	
	S412	QSW0683-001Z	PUSH SWITCH	
	S413	QSW0683-001Z	PUSH SWITCH	
	S417	QSW0683-001Z	PUSH SWITCH	
	S418	QSW0683-001Z	PUSH SWITCH	
	S419	QSW0683-001Z	PUSH SWITCH	
	S420	QSW0683-001Z	PUSH SWITCH	
	X401	GAX0112-001Z	RESONATOR I.M	
	X601	GAX0257-001Z	RESONATOR I.M	
	CN314	QGF1205C1-27	CONNECTOR	
	CN412	EWS265-A430	SOCKET WIRE ASSY	
	CN421	EWS26D-A408J	SOCKET WIRE ASSY	
	CN431	QGA2001C1-13	13P PLUG ASSY	
	CN601	QGB2510K1-08	CONNECTOR	
	CN602	QGB2510K1-09	CONNECTOR	
	CN701	QGB2510K1-10	CONNECTOR	
	CN703	QGB2510K1-05	CONNECTOR	
	CN712	QGA2001F1-06	6P PLUG ASSY	
	CN811	QGF1205C1-13	CONNECTOR	
	D1401	QLF0002-001	FLUORESCENT DISPLAY TUBE	
	FH001	E309106-001SM	FL HOLDER	
	FS001	E3400-444	FELT SPACER	
	FS002	E3400-444	FELT SPACER	
	HL401	VYH7653-001	I.C. PROTECTOR	
	HL601	VYH7237-002	I.C. COVER	
	JS401	QSW0502-001	SW	

- MEMO -

RX554RBK

■ Accessories List

Block No. M2MM

△	Item	Parts Number	Parts Name	Q' ty	Description	Area
	1	LET0118-001A	INSTRUCTION BOOK	1		E EE
		LET0118-002A	INSTRUCTION BOOK	1		EN
		LET0118-003A	INSTRUCTION BOOK	1		B
	2	E43486-340A	SAFETY SHEET	1		B
	3	BT-54008-1	WARRANTY CARD	1		
	4	BT-54011-1	LIFETIME SHEET	1		EE
	5	EWP503-001	ANTENNA WIRE	1		
	6	QAL0014-001	AM LOOP ANT	1		
	7	RM-SR554RUKP	WIRE-LESS REMOTE CONTROL	1		
	8	R6SPTT-2STS	BATTERY	1		
	9	QPA02503505P	POLY BAG	1		

Packing Materials and Parts Numbers

Block No. M 3 MM

< E/EE/EN Only >

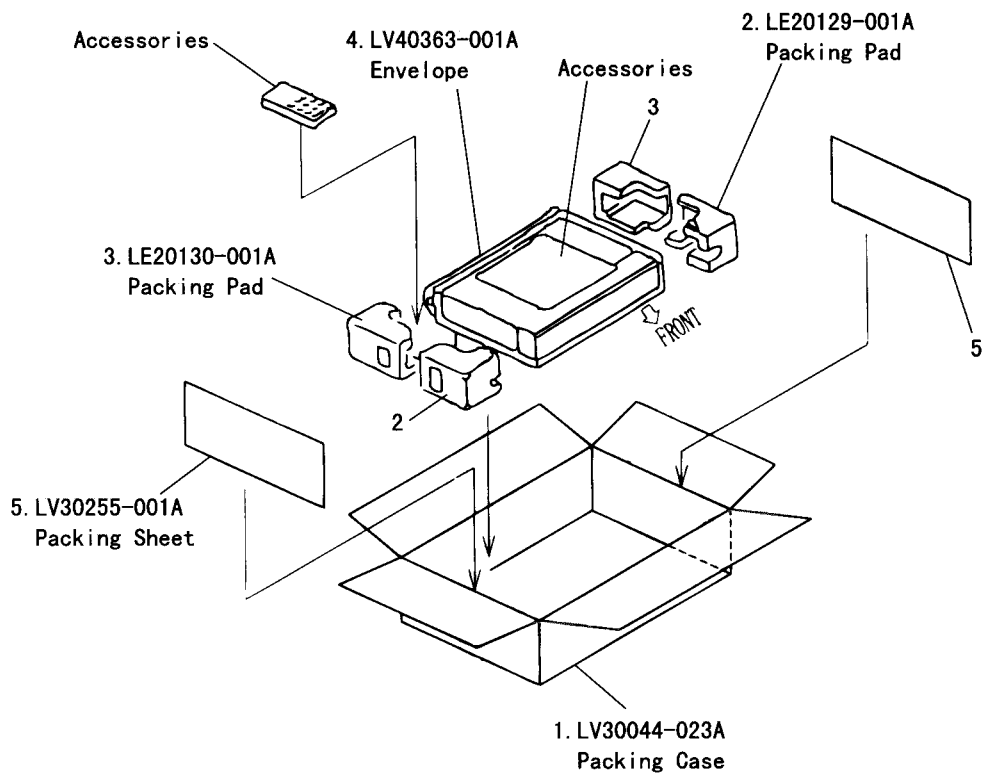

< B Only >

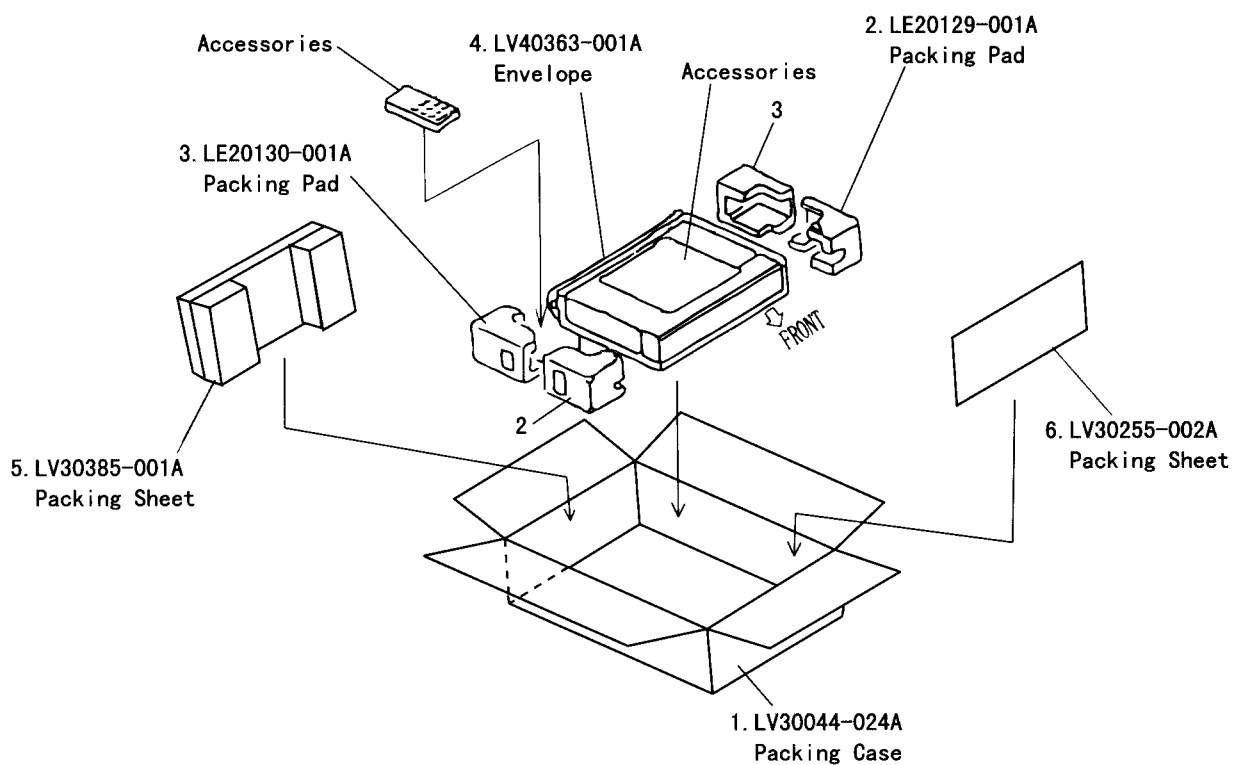

RX-554RBK_E

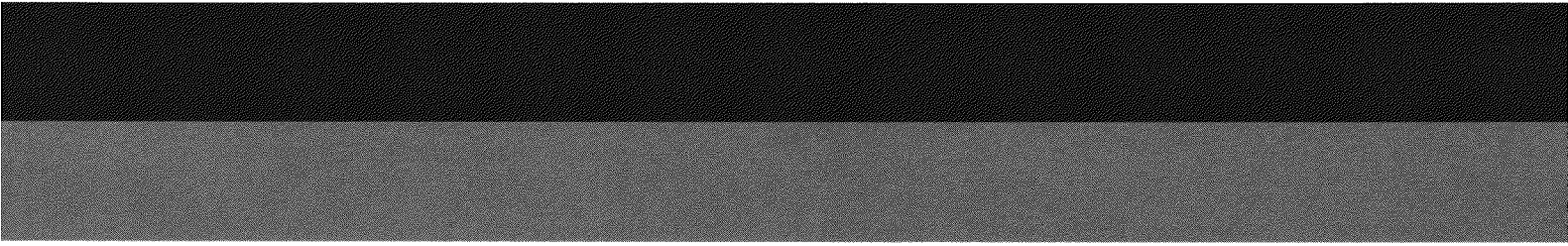

JVC

VICTOR COMPANY OF JAPAN, LIMITED
AUDIO DIVISION, 10-1, 1Chome, Ohwatari-machi, maebashi-city, 371-8543, Japan